

Blade™

PRODUCT REFERENCE GUIDE



Image Based Industrial Reader

Datalogic S.r.l.

Via S. Vitalino, 13
40012 Calderara di Reno (BO)
Italy
Tel. +39 051 3147011
Fax +39 051 3147205

This manual refers to software version 1.13.1 and later.

©2024 Datalogic S.p.A. and /or its affiliates

All rights reserved. Without limiting the rights under copyright, no part of this documentation may be reproduced, stored in or introduced into a retrieval system, or transmitted in any form or by any means, or for any purpose, without the express written permission of Datalogic S.p.A. and/or its affiliates.

Owners of Datalogic products are hereby granted a non-exclusive, revocable license to reproduce and transmit this documentation for the purchaser's own internal business purposes. Purchaser shall not remove or alter any proprietary notices, including copyright notices, contained in this documentation and shall ensure that all notices appear on any reproductions of the documentation.

Electronic versions of this document may be downloaded from the Datalogic website (www.datalogic.com). If you visit our website and would like to make comments or suggestions about this or other Datalogic publications, please let us know via the "Contact" page.

Disclaimer

Datalogic has taken reasonable measures to provide information in this manual that is complete and accurate, however, Datalogic shall not be liable for technical or editorial errors or omissions contained herein, nor for incidental or consequential damages resulting from the use of this material. Datalogic reserves the right to change any specification at any time without prior notice.

Trademarks

Datalogic and the Datalogic logo are registered trademarks of Datalogic S.p.A. in many countries, including the U.S.A. and the E.U.

Blade, ID-NET, DL.CODE, and X-PRESS are trademarks of Datalogic S.p.A. and/or its affiliates.

Digimarc® and DWCODE™ are trademarks of Digimarc Corporation. All other trademarks and brands are property of their respective owners.

This is an OPC UA-based product.

Patents

See www.patents.datalogic.com for patent list.

TABLE OF CONTENTS

PREFACE	VI
About this Manual	vi
Manual Conventions	vi
Technical Support	vi
Support Through the Website	vi
Reseller Technical Support	vii
Warranty	vii
COMPLIANCE	VIII
General	viii
Power Supply	viii
LED Safety	viii
European Declaration of Conformity	viii
UKCA Declaration of Conformity	viii
FCC Compliance	viii
EAC Compliance	ix
Important Warnings	ix
HANDLING	11
INTRODUCTION	13
Product Description	13
Applications	13
Highlights	14
Power of imaging	14
Lean integration	14
Simple installation: fix-plug-go	14
Reduced maintenance	14
Model Description	15
Available Models	15
General View	16
Indicator and Push Button	17
360° Visual Feedback	18
RAPID CONFIGURATION	19
Step 1 - Fix	19
Focus Adjustment (Blade 200 models only)	20
Step 2 - Plug	21
Step 3 - Go	22
INSTALLATION	23
Package Contents	23
Mechanical Dimensions	24
Ethernet models	25
Mounting screws length	25
Fieldbus models	26
Mounting screws length	26
Mounting And Positioning Blade	27
ELECTRICAL CONNECTIONS	29
CBX100/CBX500 Pinout for Blade	30
CAB-DS0x-S Pinout	31

CAB-GD0x-S Pinout	32
CS-A1-02-x-xx Pinout	33
Power Supply	34
Main Serial Interface	35
RS232 Interface	35
RS422 Full Duplex Interface	36
ID-NET Interface	37
Auxiliary RS232 Interface	42
Inputs	43
External Trigger Input Connections Using Blade Power	44
External Trigger Input Connections Using External Power	46
Input 2 Connections Using Blade Power	47
Input 2 Connections Using External Power	47
Input 3 Connections (CBX500 Only)	48
Outputs	49
Output 1 and 2 Connections Using Blade Power	50
On-Board Ethernet Interface	51
User Interface - Serial Host	52
TYPICAL LAYOUTS	53
Ethernet Connection	54
Serial Connection	56
Pass-Through	57
ID-NET	58
ID-NET Synchronized Network	58
ID-NET Multidata Network (Pass-Through)	62
Fieldbus	64
Profinet-IO	64
Ethernet-IP	64
Fieldbus accessories for Ethernet models	65
SET UP	66
Configuration using Web Discovery	66
X-PRESS Human Machine Interface	68
X-PRESS™ Interface Details	69
X-PRESS Functions	69
Button procedures	70
Aim	70
Test Mode	70
Learn	71
Init	71
Diagnostic Indication	71
READING FEATURES	72
FOV Calculation	72
Reading Diagrams	73
Blade 100 - 2x0x	73
Blade 100 - 1x0x	74
Blade 200 - xx0x - focus=Near	75
Blade 200 - xx0x - focus=Mid	76
Blade 200 - xx0x - focus=Far	77
Consideration on label moving speed	78
“Picket Fence” reading mode	78
Code Width and Frame Rate	78
Blur effect and Exposure Time	79
“Step Ladder” reading mode	80
Code Width and Frame Rate	80
Blur effect and Exposure Time	80
DL.CODE SOFTWARE CONFIGURATION	81
DL.CODE System Requirements	81
Configuration Using DL.Code	82
Installing DL.CODE Configuration Program	82
Device Discovery	83

Device Configuration	85
Code Settings	86
Reading Phase	87
Good Read Setup	88
Data Formatting	89
Output Setup	90
Host Mode Programming	91
Manual Calibration	91
Under-exposure	91
Over-exposure	92
Moving code out of the Field of View	93
Pass-Through Configurations	94
Internal Network Configurations	96
Master Configuration	97
Multidata ID-NET Network Configurations	99
Synchronized ID-NET Network Configurations	103
Verify Master/Slave Synchronized Configuration	106
Diagnostic Alarms	108
Statistics	109
BM150 Display Module Configuration and Messages	110
Configuration Through DL.CODE	110
Accessing the HMI Interface Through Keypad and Display Menu	111
Display Messages	113
BM150 Backup and Restore Procedure	117
BACKUP AND RESTORE	118
Backup and Restore Through Micro SD Card	118
Backup and Restore Through DL.CODE	119
Backup	120
Restore	121
Replacement	121
Restore Defaults	122
Restore Default Startup Configuration	122
Restore Default Environment	123
Restore Factory Defaults	123
MAINTENANCE	124
Cleaning	124
TROUBLESHOOTING	125
General Guidelines	125
TECHNICAL FEATURES	128
ALTERNATIVE CONNECTIONS	131
Ethernet Models	132
Power, Com and I/O connector	132
Ethernet connector	132
Fieldbus Models	133
Power and I/O connector	133
Ethernet connector 1	133
Ethernet connector 2	133
ID-NET Network Termination	134
Inputs	135
Outputs	135
User Interface - Serial Host	137
ACCESSORIES	138
Mounting Bracket	138
Rod Mount Kit	139
Other Available Accessories	140
GLOSSARY	142

PREFACE

ABOUT THIS MANUAL

This Product Reference Guide (PRG) is provided for users seeking advanced technical information, including connection, programming, maintenance and specifications. The Quick Reference Guide (QRG) and other publications associated with this product can be downloaded free of charge from the website listed on the back cover of this manual.

Manual Conventions

The following conventions are used in this document:

The symbols listed below are used in this manual to notify the reader of key issues or procedures that must be observed when using the reader:



NOTE: Notes contain information necessary for properly diagnosing, repairing and operating the reader.



CAUTION: This symbol advises you of actions that could damage equipment or property.



WARNING: This symbol advises you of actions that could result in harm or injury to the person performing the task.

TECHNICAL SUPPORT

Support Through the Website

Datalogic provides several services as well as technical support through its website. Log on to (www.datalogic.com).

For quick access, from the home page click on the search icon , and type in the name of the product you're looking for. This allows you access to download Data Sheets, Manuals, Software & Utilities, and Drawings.

Hover over the Support & Service menu for access to Services and Technical Support.

Reseller Technical Support

An excellent source for technical assistance and information is an authorized Datalogic reseller. A reseller is acquainted with specific types of businesses, application software, and computer systems and can provide individualized assistance.

WARRANTY

Datalogic warrants that the Products shall be free from defects in materials and workmanship under normal and proper use during the Warranty Period. Products are sold on the basis of specifications applicable at the time of manufacture and Datalogic has no obligation to modify or update Products once sold. The Warranty Period shall be **three years** from the date of shipment by Datalogic, unless otherwise agreed in an applicable writing by Datalogic.

Datalogic will not be liable under the warranty if the Product has been exposed or subjected to any: (1) maintenance, repair, installation, handling, packaging, transportation, storage, operation or use that is improper or otherwise not in compliance with Datalogic's instruction; (2) Product alteration, modification or repair by anyone other than Datalogic or those specifically authorized by Datalogic; (3) accident, contamination, foreign object damage, abuse, neglect or negligence after shipment to Buyer; (4) damage caused by failure of a Datalogic-supplied product not under warranty or by any hardware or software not supplied by Datalogic; (5) any device on which the warranty void seal has been altered, tampered with, or is missing; (6) any defect or damage caused by natural or man-made disaster such as but not limited to fire, water damage, floods, other natural disasters, vandalism or abusive events that would cause internal and external component damage or destruction of the whole unit, consumable items; (7) use of counterfeit or replacement parts that are neither manufactured nor approved by Datalogic for use in Datalogic-manufactured Products; (8) any damage or malfunctioning caused by non-restoring action as for example firmware or software upgrades, software or hardware reconfigurations etc.; (9) loss of data; (10) any consumable or equivalent (e.g. cables, power supply, batteries, etc.); or (11) any device on which the serial number is missing or not recognizable.

THE DATALOGIC WARRANTIES ARE EXCLUSIVE AND IN LIEU OF ALL OTHER WARRANTIES, WHETHER WRITTEN, EXPRESS, IMPLIED, STATUTORY OR OTHERWISE, INCLUDING, BUT NOT LIMITED TO, THE IMPLIED WARRANTIES OF MERCHANTABILITY AND FITNESS FOR PARTICULAR PURPOSE. DATALOGIC SHALL NOT BE LIABLE FOR ANY DAMAGES SUSTAINED BY BUYER ARISING FROM DELAYS IN THE REPLACEMENT OR REPAIR OF PRODUCTS UNDER THE ABOVE. THE REMEDY SET FORTH IN THE WARRANTY STATEMENT IS THE BUYER'S SOLE AND EXCLUSIVE REMEDY FOR WARRANTY CLAIMS. NO EXTENSION OF THIS WARRANTY WILL BE BINDING UPON DATALOGIC UNLESS SET FORTH IN WRITING AND SIGNED BY DATALOGIC'S AUTHORIZED REPRESENTATIVE. DATALOGIC'S LIABILITY FOR DAMAGES ON ACCOUNT OF A CLAIMED DEFECT IN ANY PRODUCT DELIVERED BY DATALOGIC SHALL IN NO EVENT EXCEED THE PURCHASE PRICE OF THE PRODUCT ON WHICH THE CLAIM IS BASED. DATALOGIC SHALL NOT BE LIABLE FOR DAMAGES RELATING TO ANY INSTRUMENT, EQUIPMENT, OR APPARATUS WITH WHICH THE PRODUCT SOLD UNDER THIS AGREEMENT IS USED. Further details on warranty coverage, rights and conditions are addressed under and regulated by the Terms and Conditions of Sales of Datalogic available at https://www.datalogic.com/terms_conditions_sales.

COMPLIANCE

GENERAL

For installation, use and maintenance it is not necessary to open the reader.

Only connect Ethernet and dataport connections to a network which has routing only within the plant or building and no routing outside the plant or building.

Power Supply

This product is intended to be installed by **Qualified Personnel** only.

This product is intended to be connected to a UL Listed Direct Plug-in Power Unit marked LPS or “Class 2”.

LED Safety

LED illuminators integrated are classified as “EXEMPT RISK GROUP” according to IEC62471.

European Declaration of Conformity

Hereby, Datalogic S.r.l. declares that the full text of the European Declaration of Conformity is available at: www.datalogic.com. Select the link from the downloads section of the product page.

UKCA Declaration of Conformity

Hereby, Datalogic S.r.l. declares that the full text of the UKCA Declaration of Conformity is available at: www.datalogic.com. Select the link from the downloads section of the product page.

FCC Compliance

Modifications or changes to this equipment without the expressed written approval of Datalogic could void the permission to use the equipment.

This laser marker complies with PART 15 of the FCC Rules. Operation is subject to the following two conditions: (1) this laser marker may not cause harmful interference, and (2) this laser marker must accept any interference received, including interference which may cause undesired operation.

This laser marker has been tested and found to comply with the limits for a Class A digital device, pursuant to part 15 of the FCC Rules. These limits are designed to provide reasonable protection against harmful interference when the equipment is operated in a commercial environment. This laser marker generates, uses, and can radiate radio fre-

quency energy and, if not installed and used in accordance with the instruction manual, may cause harmful interference to radio communications. Operation of this laser marker in a residential area is likely to cause harmful interference in which case the user will be required to correct the interference at his/her own expense.

EAC Compliance

Customs Union: this laser marker complies with CU Conformity certification; this allows the Product to bear the Eurasian Mark of conformity.

IMPORTANT WARNINGS

Access to the internal parts of the product is allowed only to authorized personnel, duly qualified and trained with regards to risks of optical and electrical nature.

Datalogic declines any and all responsibility for work carried out on active parts by untrained or unauthorized personnel.



CAUTION: It is forbidden to change the intended use for which the product was designed and developed.

Datalogic declines any and all responsibility for improper use of its product.



CAUTION: It is the responsibility of the customer to install the product in proper safety condition!

HANDLING

The Blade is designed to be used in an industrial environment and is built to withstand vibration and shock when correctly installed, however it is also a precision product and therefore before and during installation it must be handled correctly to avoid damage.



CAUTION: Avoid that the readers are dropped (exceeding shock limits).

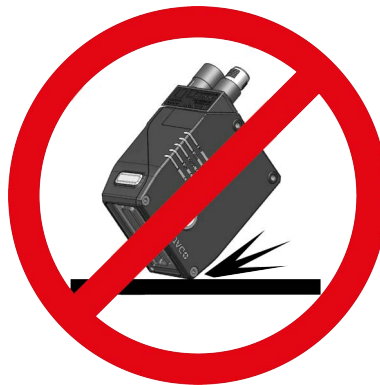

CAUTION: DO NOT fine tune the positioning by striking the reader or bracket.





CAUTION: DO NOT weld the reader into position which can cause electrostatic, heat or reading window damage.



CAUTION: DO NOT spray paint near the reader which can cause reading window damage.



CHAPTER 1

INTRODUCTION

PRODUCT DESCRIPTION

Blade Series is the new generation of Compact Industrial 1D Readers designed for lean integration, simple installation and reduced maintenance.

Blade represent the R-Evolution of heroic DS2X000 Series:

- Revolution: Blade is adopting Imaging technology (no laser, no moving parts, all electronics) ensuring maximum reading performances over 1D barcodes and unsurpassed reliability.
- Evolution: Blade is fully backward compatible in terms of mechanical installation and reading coverage (distance, barcode resolution, connectivity) with DS2x00.

Blade models provide ready-to-use, cutting edge solutions supporting a variety of Traceability applications in OEM, Factory and Warehousing Automation, whenever 1D barcodes are in use.

Main Sub-Industry targets are Packaging (Pharma, Food & Beverage) and Intralogistics (Warehouse Automation and general Intralogistics).

Main applications: Tote Routing, primary and secondary packaging traceability, end of line traceability/sorting.

The Series is made of two product versions, Blade 100 and Blade 200, offering increasing reading power and flexibility to efficiently match different application needs.

Applications

- Automatic warehouses
- General intra-logistics
- Tote routing
- Factory automation
- Automatic picking systems
- Process control and packaging traceability (Pharma, Food & Beverage)
- Print & Apply systems
- End of line traceability/sorting

Highlights

Power of imaging

- Camera sensor 1920 x 128 pixels and innovative lighting system
- Improved reliability, increased reading performances on poor quality labels and 50% reduction of models

Lean integration

- Small size, various fixing points and embedded flexibility allows different positions and orientations
- Smooth transition from DS2X00 to Blade ensured through same mechanical dimensions, positioning and performance

Simple installation: fix-plug-go

- FIX is easy, every needed position/angle is supported by multiple fixing point
- PLUG M12 connectors for both I/O and Networking. Three options available: single port TCP/IP ETHERNET plus Legacy RS-232, Double PORT PROFINET and Double Port ETHERNET/IP
- GO: switch on and BLADE is ready to start. No image calibration needed. Blade is configured via DL.CODE, the standard tool for Matrix Series

Reduced maintenance

- Elimination of moving parts: full electronics components will improve product lifetime and reduce total cost of ownership
- In case of replacement configuration backup/restore is available both over the Network and locally via the new MicroSD Card slot
- Complete Monitoring options are offered: embedded WebMonitor (same as Matrix Series) freely accessible and connection to WebSentinel Plus ecosystem

MODEL DESCRIPTION

Blade readers are described by their model number which indicates the characteristics listed in the diagram below. Not all combinations are available. For a complete list of combinations see the Models tab on the Product page of the website.

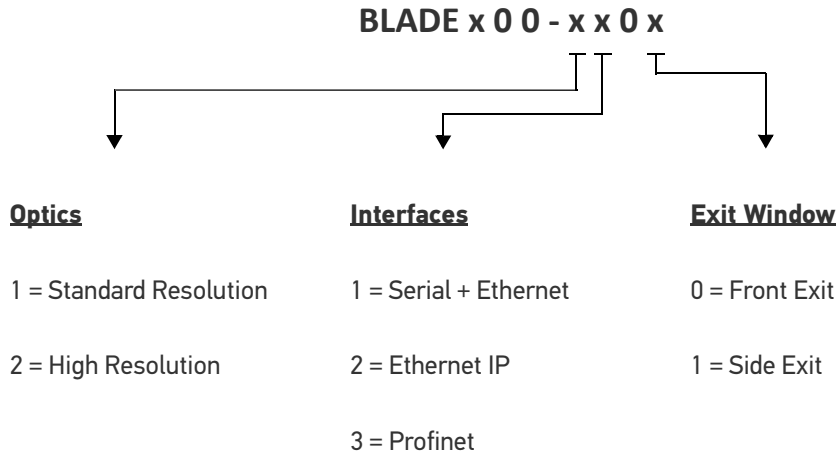

Available Models

Part Number	Description
930190001	BLADE 100 2100 HI-RES ETH FRONT
930190002	BLADE 100 1100 ETH FRONT
930190003	BLADE 100 1101 ETH SIDE
930190004	BLADE 100 1201 ETH-IP SIDE
930190005	BLADE 100 1301 PNET SIDE
930190007	BLADE 200 1100 ETH FRONT
930190008	BLADE 200 1101 ETH SIDE
930190009	BLADE 200 1200 ETH-IP FRONT
930190010	BLADE 200 1201 ETH-IP SIDE
930190011	BLADE 200 1300 PNET FRONT
930190012	BLADE 200 1301 PNET SIDE

GENERAL VIEW

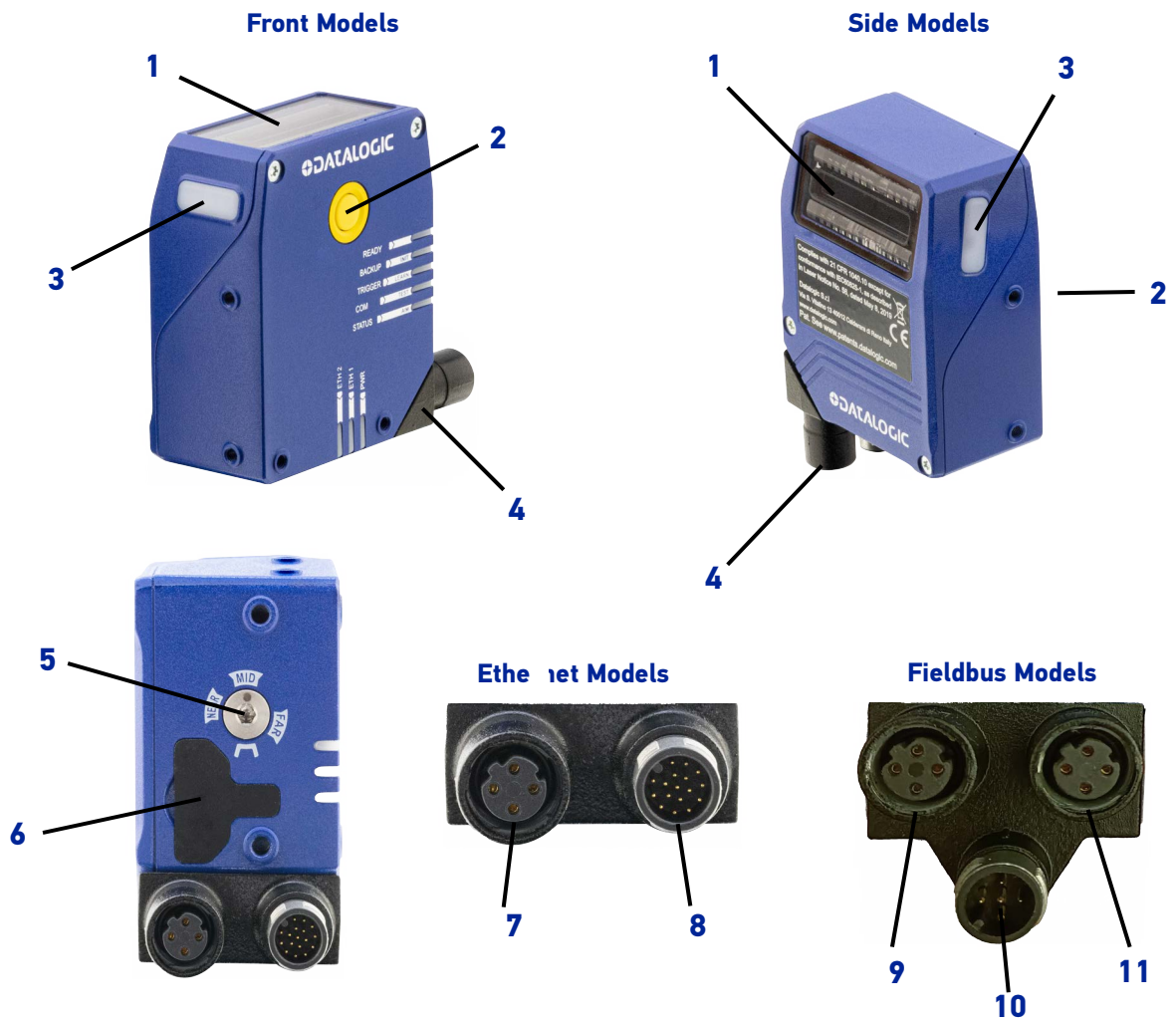

Figure 1 - General View

1. Reading Window	7. Ethernet Connector (4 pin)
2. HMI X-PRESS™ Interface	8. Power - COM - I/O Connector (17 pin)
3. 360° Visual Feedback	9. Ethernet Connector 1 (4 pin)
4. 90° Rotating Connector Block	10. Power - I/O Connector (5 pin)
5. Focus adjustment (Blade 200 models only)	11. Ethernet Connector 2 (4 pin)
6. SD Card slot	

INDICATOR AND PUSH BUTTON



Figure 2 - Indicators

The following LED indicators are located on the reader:

PWR	blue LED indicates that the reader is connected to the power supply (Figure 2, 8)
ETH1	yellow LED indicates connection to the on-board Ethernet network 1 (Figure 2, 7)
ETH2	yellow LED indicates connection to the on-board Ethernet network 2 (Figure 2, 6) ¹

1. Available depending on the model.

In normal operating mode the colors and meaning of the five LEDs are illustrated in the following table:

READY	green, indicates the device is ready to operate (Figure 2, 1)
BACKUP	green, indicates that a valid Backup is present on the SD card (Figure 2, 2)
TRIGGER	yellow, indicates the status of the reading phase (Figure 2, 3)
COM	yellow, indicates active communication ¹ (Figure 2, 4)
STATUS	red, blinks together with Ready led to indicate an active diagnostic message (Figure 2, 5)

1. When connected to a Fieldbus network through the CBX500, the COM LED is always active, even in the absence of data transmission, because of polling activity on the Fieldbus network.

During the reader startup (reset or restart phase), these five LEDs blink for one second. In X-PRESS Configuration mode the colors and meaning of these five LEDs are described in “X-PRESS Human Machine Interface” on page 68.

The push button (Figure 2, 9), is software programmable. By default it starts the X-PRESS interface for quick installation without using a PC.

360° VISUAL FEEDBACK

Blade is equipped with a 360° Visual Feedback through colored LEDs mounted on both side to provide immediate feedback on the device status during operation.



Figure 3 - 360° Visual Feedback

The available colors are activated by the following default events:

- Blue = Configuration Mode
- Green = Good Read
- Red = No Read

On DL.CODE it is possible to select the events that will activate 360° Feedback (e.g. Communication Channel Strings, Inputs, Read Events, Operating Mode, Script Events). To do this, go to *Output Setup > LEDs*

CHAPTER 2

RAPID CONFIGURATION

Blade models can be ready-to-use in three steps:

- "Step 1 - Fix" on page 19
- "Step 2 - Plug" on page 21
- "Step 3 - Go" on page 22

STEP 1 - FIX

1. To mount the Blade, use the dedicated threaded holes to obtain the most suitable position for the reader. There are two different mounting possibilities:

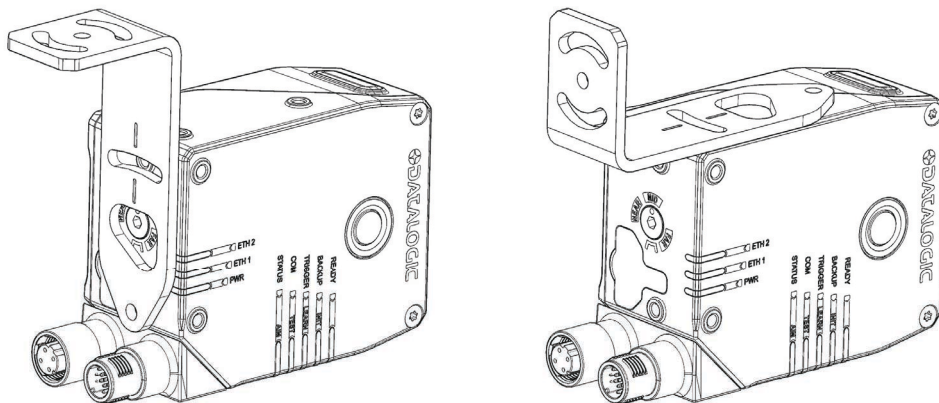

Figure 4 - Positioning with Mounting Bracket



NOTE: Refer to chapter "Installation" on page 23 for detailed fixing information.



NOTE: The Mounting Bracket is available as an accessory (see "Mounting Bracket" on page 138).



NOTE: The Mounting Bracket is included for Blade 200 models only.

2. When mounting the Blade take into consideration these three ideal label position angles: **Pitch: minimize, Skew: ensure at least 10°, Tilt: any angle inside the FOV.**

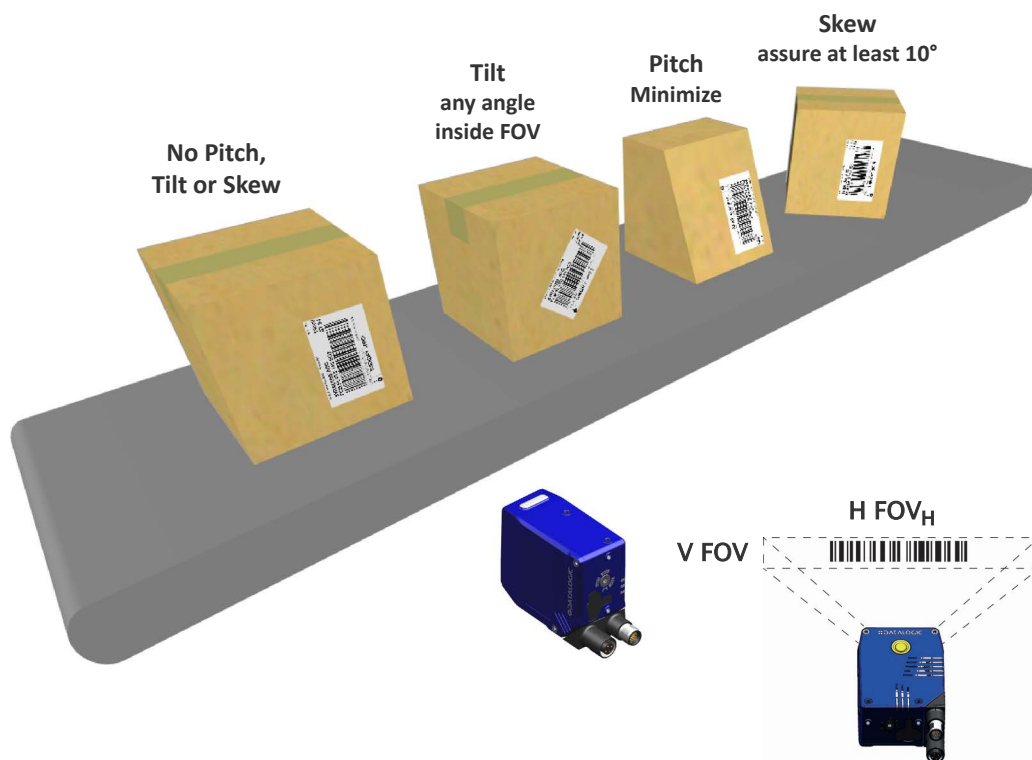

Figure 5 - Pitch, Skew and Tilt References

3. Refer to the reading diagrams in [Chapter 7, Reading Features](#) to determine the distance your reader should be positioned at.



NOTE: Rapid Configuration of the Blade reader can be made either through the X-PRESS interface (see “X-PRESS Human Machine Interface” on page 68) which requires no PC connection, or by using the DL.CODE Configuration Program (see “Configuration Using DL.Code” on page 82). Select the procedure according to your needs.



NOTE: The reading area is approximately in the center of the illuminated band. For a more precise aiming use:

- the Aim X-Press function (see “Aim” on page 70)
- the web monitor tool (refer to DL.Code user manual)

Focus Adjustment (Blade 200 models only)

In Blade 200 Models the focus position can be set using the focusing adjusting knob on the rear of the product.

There are 3 main focus position: “Near”, “Mid”, “Far”.

Using a 3 mm Allen wrench to turn the focusing knob, choose the one more suitable for your application according to the corresponding reading diagram (see “Reading Diagrams” on page 73). By default optimal image settings (Exposure Time and Gain) for each focus position are automatically applied.

If needed these values can be overridden with DL.Code unchecking the “Standard Image Settings” flag in DL.Code (see “DL.CODE Software Configuration” on page 81).

STEP 2 - PLUG



NOTE: In order to improve ease of installation and maintenance it is possible to use the X-PRESS HMI. Refer to chapter “X-PRESS Human Machine Interface” on page 68 for further information about the X-Press HMI.

To connect the reader in a Stand Alone configuration, you need the hardware indicated in Figure 6. In this layout the data is transmitted to the Host on the Ethernet interface. Data can also be transmitted on the RS232 main and/or auxiliary interface independently from the Ethernet interface selection.

This layout refers to the default configuration, with the reader in Phase Mode and the reading phase is activated by an External Trigger (photoelectric sensor) when the object enters its reading zone.

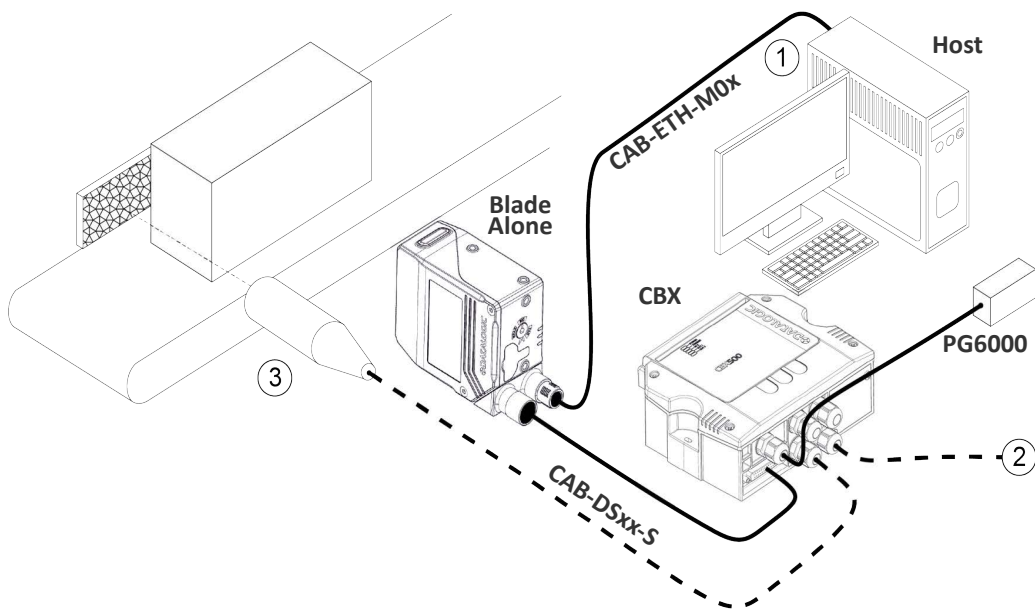

- 1 - Ethernet Interface
- 2 - Auxiliary Serial Interface (RS232 - Data Monitor)
- 3 - External Trigger (for Phase Mode. See “Sensors” on page 141. for more details)

Figure 6 - Blade in Stand Alone Layout



NOTE: Refer to chapter “DL.CODE Software Configuration” on page 81 to setup other configuration.



NOTE: Refer to chapter “Electrical Connections” on page 29 for detailed wiring connection.

STEP 3 - GO

The device is now ready to function, with the following default configuration:

- IP Address: **192.168.3.100**
- Operating Mode: Phase Mode
- Phase On: Input 1 Leading Edge
- Phase Off: Input 1 Trailing Edge
- Good Read Setup: Code collection, min code = 1, max code = 1
- Enabled decoding slots:
 - Slot1: Code 128
 - Slot2: Code39
 - Slot3: INT2OF5 (Min Char = 4)
- Output message channel: Reader TCP server, port 51236
- Success Message: <STX>CodeContent<CR><LF>
- Failure Message: <STX><CAN><CR><LF>



NOTE: If you need to change this configuration use **DL.Code** configuration program (see chapter “**DL.CODE Software Configuration**” on page 81). This configuration refers to the Ethernet models (x00-x10x). For the default configuration of Fieldbus models refer to the specific documentation.



NOTE: The “**Web Discovery**” feature is available to quickly change the device IP Address (see “**Configuration using Web Discovery**” on page 66).



NOTE: The configuration in use can be saved via SD Card (see “**Backup and Restore Through Micro SD Card**” on page 118 for further information).



NOTE: The default image settings parameters are optimized to fit the vast majority of the applications, so there is usually no need to change them.

CHAPTER 3

INSTALLATION

PACKAGE CONTENTS

Before installing or operating the reader, you should:

- Inspect the shipping container for damage
- Inspect the reader for signs of damage
- Confirm that the shipping box contains all items on the shipping inventory list including any accessories

When unpacking the reader from the shipping box you should:

- Remove the accessories and documentations
- Carefully remove the reader from the packaging

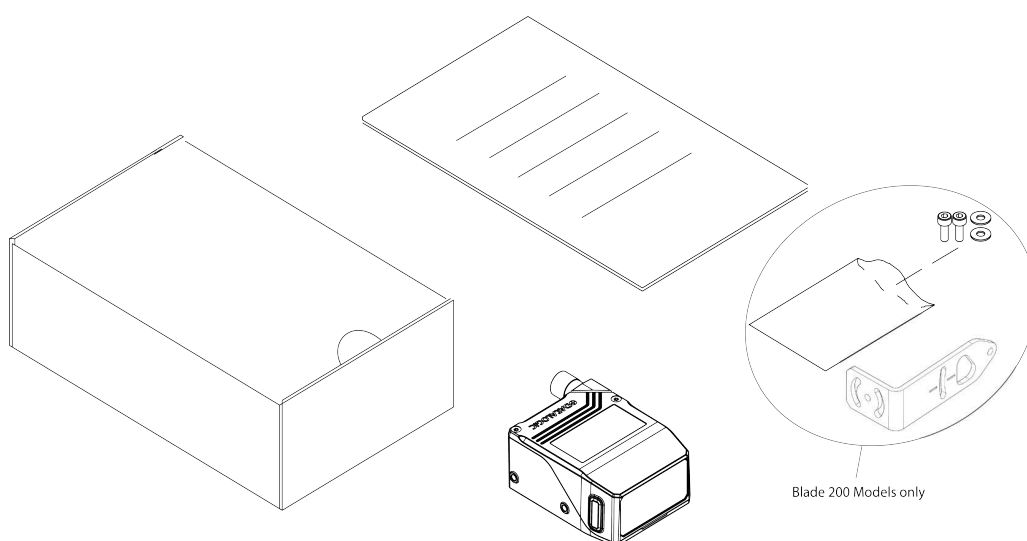

Figure 7 - Package Contents

Keep all packing materials until the reader has been inspected for completeness and damage. If something is missing or defective, call Datalogic (see “Technical Support” on page vi for contact details).

Be sure to use the original packaging material for the transportation of this reader, otherwise transportation could cause malfunctions or damage. Keep the original packaging materials for future use. Be careful to ship the reader following the recommendations present in the packaging labels.

MECHANICAL DIMENSIONS

Blade can be installed to operate in different positions. The screw holes (M4 x 5mm depth) placed on the body of the reader are for mechanical fixture.

The next diagrams give the overall dimensions of the reader and may be used for its installation.



NOTE: Refer to “Mounting And Positioning Blade” on page 27 for various mounting solutions and correct positioning.



NOTE: Refer to “Reading Features” on page 72 for FOV vs. Reading Distance considerations.

Ethernet models

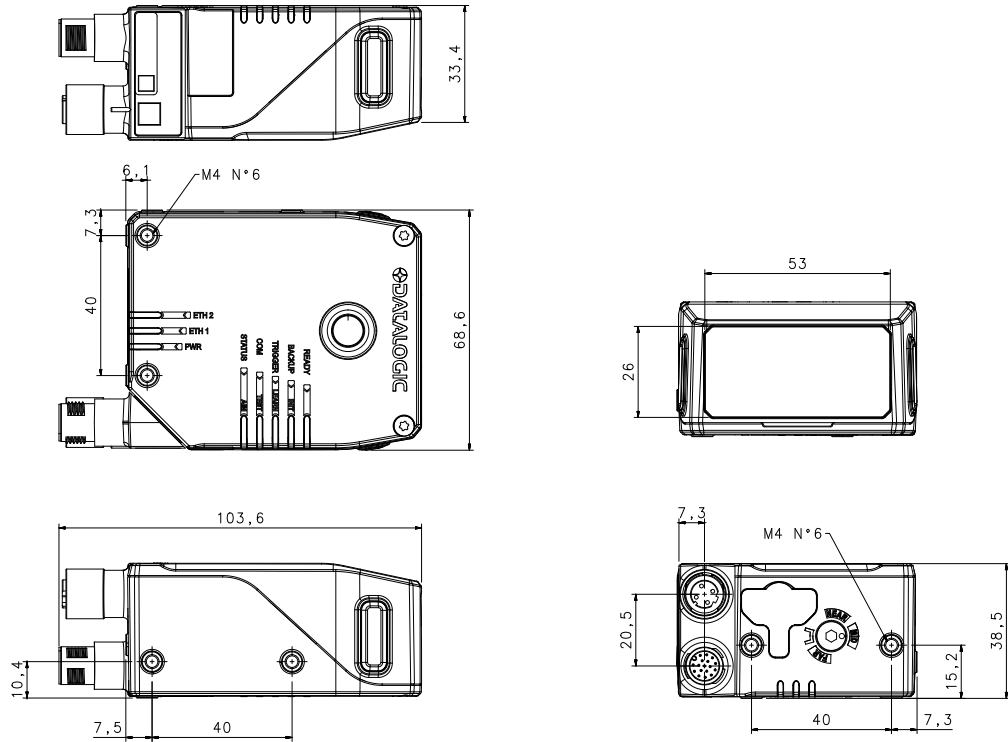

Figure 8 - Overall Dimensions front window models



NOTE: All dimensions are in millimeters.

Mounting screws length

To determine the length of the mounting screws, consider the thickness of the mounting plate and the thickness of the washer.

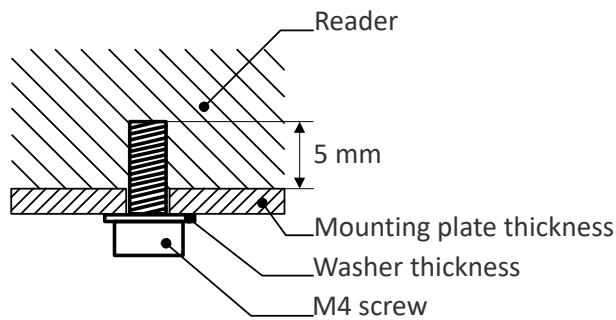

Figure 9: Length of mounting screws



NOTE: Mounting holes depth is = 5mm. Tightening torque = 2 Nm.

Fieldbus models

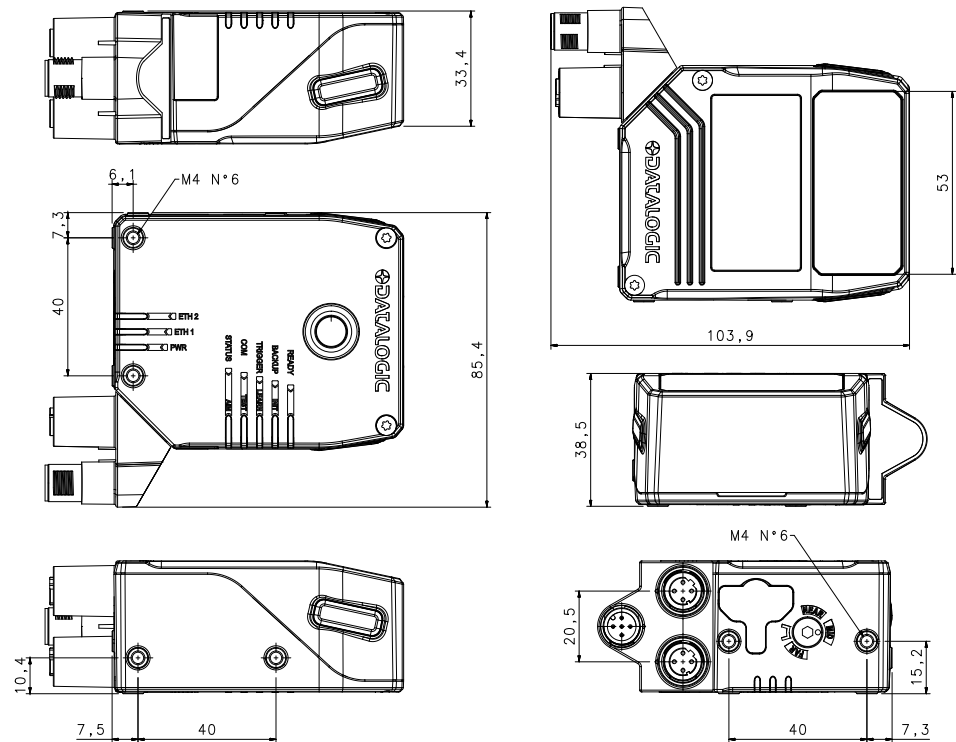

Figure 10 - Overall Dimensions side window models



NOTE: All dimensions are in millimeters.

Mounting screws length

To determine the length of the mounting screws, consider the thickness of the mounting plate and the thickness of the washer.

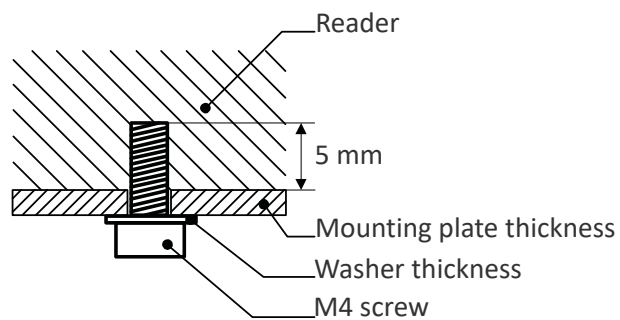

Figure 11: Length of mounting screws



NOTE: Mounting holes depth is = 5mm. Tightening torque = 2 Nm.

MOUNTING AND POSITIONING BLADE

Using the Blade mounting bracket (accessory available for Blade 100 models and included for Blade 200 models) it is possible to obtain three types of mounting of the reader as shown in the diagram below:

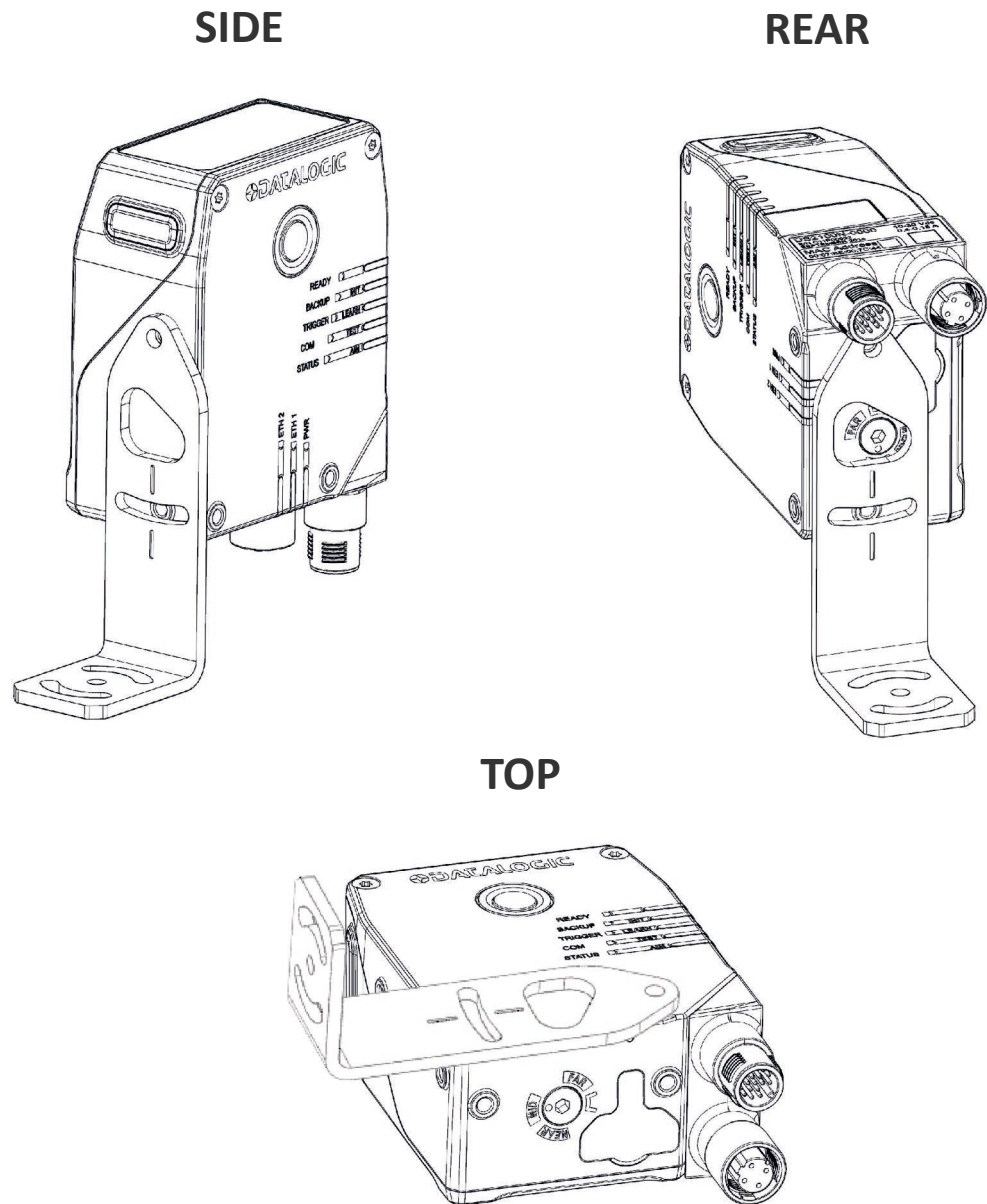

Figure 12 - Positioning with Mounting Bracket

Blade is able to decode code labels at a variety of angles; however significant angular distortion may degrade reading performance.

When mounting the Blade take into consideration these three ideal label position angles: **Pitch: minimize, Skew: ensure at least 10°, Tilt: any angle inside the FOV.**

The **Pitch, Skew and Tilt** angles are represented in Figure 13. Follow the suggestions below for the best orientation:

Position the reader in order to avoid the direct reflection of the light emitted by the Blade reader; it is advised to **assure at least 10°** for the Skew angle.

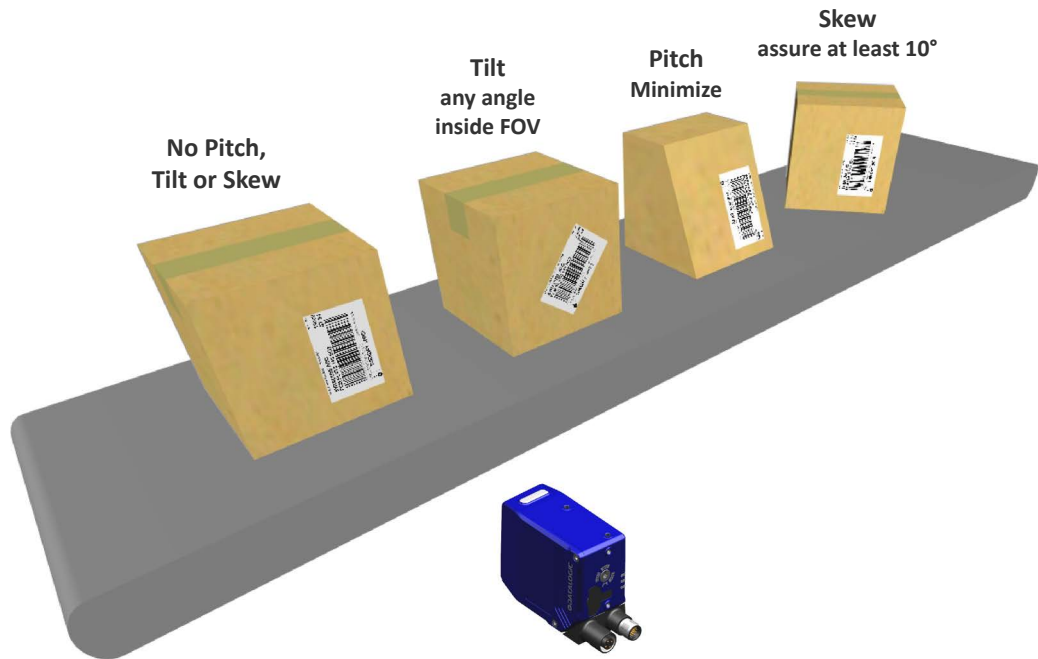

Figure 13 - Code Reading Orientation

The **Tilt** angle is also represented in Figure 14. Blade can read labels with any tilt angle. Keep in mind however, that since linear barcodes are rectangular, the reader should be aligned to fit them into the horizontal FOV.



Figure 14 - Tilt Angle Considerations



NOTE: See “Reading Features” on page 72 for FOV vs. Reading Distance considerations.

CHAPTER 4

ELECTRICAL CONNECTIONS

All Blade Standard Input Power models can be connected to a CBX connection box through one of the available **CAB-DSxx-S** accessory cables. These accessory cables terminate in an M12 17-pin connector on the Blade side and in a 25-pin male D-sub connector on the CBX side.

We recommend making system connections through one of the CBX connection boxes since they offer the advantages of easy connection, easy device replacement, opto-isolated outputs (Outputs 1 and 2), and filtered reference signals.



NOTE: If you require direct wiring to the reader the connections are the same as shown in this chapter with the exception of the digital Outputs. Direct wiring details are indicated in Appendix A.

CBX100/CBX500 PINOUT FOR BLADE

The table below gives the pinout of the CBX100/CBX500 terminal block connectors. Use this pinout when the Blade reader is connected by means of the CBX100/CBX500:

GROUP	LABEL	DESCRIPTION
Input Power	Vdc	Power Supply Input Voltage +
	GND	Power Supply Input Voltage -
	Earth	Protection Earth Ground
Inputs	+V	Power Source - External Trigger
	I1A	External Trigger A (polarity insensitive)
	I1B	External Trigger B (polarity insensitive)
	-V	Power Reference - External Trigger
	+V	Power Source - Inputs
	I2A	Input 2 A (polarity insensitive)
	I2B	Input 2 B (polarity insensitive)
Outputs	+V	Power Source - Outputs
	-V	Power Reference - Outputs
	O1+	Output 1 + opto-isolated and polarity sensitive
	O1-	Output 1 - opto-isolated and polarity sensitive
	O2+	Output 2 + opto-isolated and polarity sensitive
	O2-	Output 2 - opto-isolated and polarity sensitive
Auxiliary Interface	TX	Transmit Data
	RX	Receive Data
	SGND	Auxiliary Interface Signal Ground
ID-NET	REF	Network Reference
	ID+	ID-NET network data +
	ID-	ID-NET network data -
	Shield	Network Cable Shield
Main Interface	RS232	RS422 Full Duplex (Blade 200 models only)
	TX	TX+
	RX	* RX+
	-	TX-
	-	* RX-
	SGND	SGND

* Do not leave floating, see "RS422 Full Duplex Interface" on page 36 for connection details.



CAUTION: Do not connect GND, SGND and REF to different (external) ground references. GND, SGND and REF are internally connected through filtering circuitry which can be permanently damaged if subjected to voltage drops over 0.8 Vdc.



NOTE: To avoid electromagnetic interference when the reader is connected to a CBX connection box, verify the jumper positions in the CBX as indicated in its Installation Manual.

CAB-DS0x-S Pinout

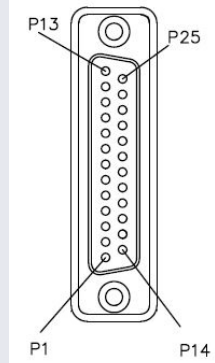
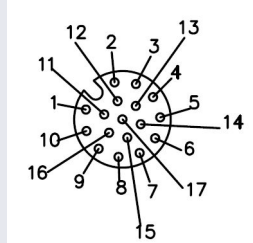

17 PINS	NAME	WIRE COLOR	25 PINS
1	VS	Red	9-13
2	GND	Black	7-25
6	XTRG_A	Orange	18
5	XTRG_B	Green/Black	19
13	IN2A	Gray	6
3	IN2B	Green/Red	10
8	OUT2	White/Red	11
9	OUT1	Purple	8
17	CO/TX	Yellow	2
11	C2/RX	Brown	3
12	C1/RTS	Pink	4
10	C3/CTS	Green	5
4	TXA	Yellow/White	21
14	RXA	Yellow/Blue	20
7	NET+	White	23
15	NET-	Blue	24
NUT	SHIELD	Both Shields	1
			12, 15, 17, 22 Not connected

CAB-GD0x-S Pinout

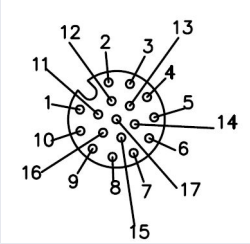
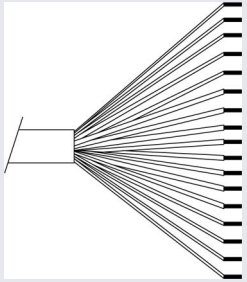
17 PINS	NAME	STRIPPED WIRE COLOR
1	VS	Brown
2	GND	Blue
6	XTRG_A	Yellow
5	XTRG_B	Pink
13	IN2A	White/Green
3	IN2B	White
16	OUT3	Yellow/Brown
8	OUT2	Gray
9	OUT1	Red
17	CO/TX	White/Gray
11	C2/RX	Gray/Pink
12	C1/RTS	Red/Blue
10	C3/CTS	Purple
4	TXA	Green
14	RXA	Brown/Green
7	NET+	Black
15	NET-	White/Yellow



CAUTION: Unused stripped wires must be insulated to prevent shorting.

CS-A1-02-x-xx Pinout

5 PINS	NAME	STRIPPED WIRE COLOR
1	Vdc	Brown
2	IA	White
3	GND	Blue
4	IB	Black
5	-	-



CAUTION: Unused stripped wires must be insulated to prevent shorting.

Power Supply

For these models power can be supplied to the reader through the CBX100/500 spring clamp terminal pins as shown in Figure 15:

Power Supply

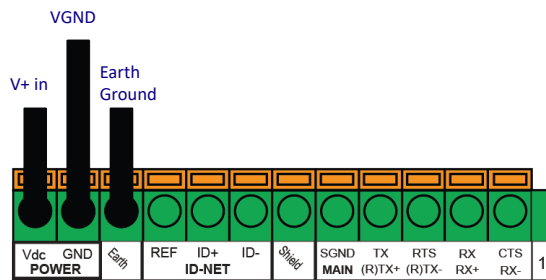

Figure 15 - Power Supply Connections

The power must be between 10 and 30 Vdc only.

It is recommended to connect the device CHASSIS to earth ground (Earth) by setting the appropriate jumper in the CBX connection box. See the CBX Installation Manual for details.

Main Serial Interface



CAUTION: Do not connect to the Main Interface spring clamp terminals if using Host Interface Modules (Fieldbus) with the CBX500.

The signals relative to the following serial interface types are available on the CBX spring clamp terminal blocks.

The main serial interface type and its parameters (baud rate, data bits, etc.) can be defined by the user via DL.CODE software. For more details refer to the Help On Line page of the Reading Phase step (Channels) in DL.CODE.

Details regarding the connections and use of the interfaces are given in the next paragraphs.

RS232 Interface

The RS232 interface is generally used for Point-to-Point connections. When it is connected to the host computer it allows transmission of code data.

The following pins are used for RS232 interface connection:

CBX100/500	Description
TX	Transmit Data
RX	Receive Data
SGND	Signal Ground

It is always advisable to use shielded cables. The overall maximum cable length must be less than 15 m (49.2 ft).

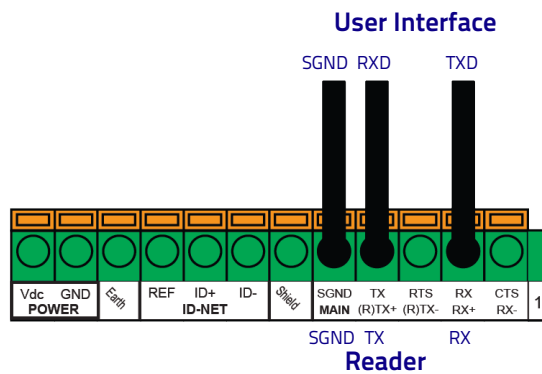

Figure 16 - RS232 Main Interface Connections

RS422 Full Duplex Interface

The RS422 full-duplex (5 wires + shield) interface is used for non-pollled communication protocols in point-to-point connections over longer distances (max 1200 m / 3940 ft) than those acceptable for RS232 communications or in electrically noisy environments.

The CBX pinout follows:

CBX100/500	Description
TX+	RS422 Transmit Data +
RX+	RS422 Receive Data +
TX-	RS422 Transmit Data -
RX-	RS422 Receive Data -
SGND	Signal Ground

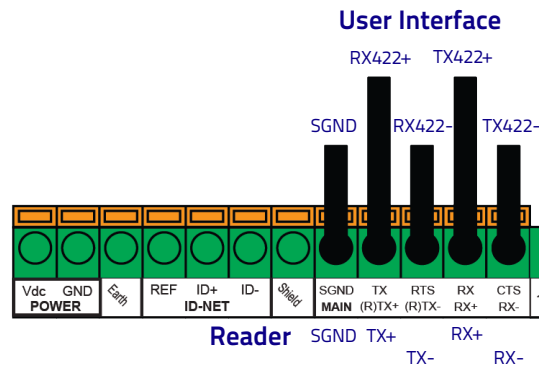

Figure 17 - RS422 Full Duplex Connections



NOTE: For applications that do not use RS422 transmission to the reader (terminal block RX+ and RX- signals), do not leave these lines floating but connect them to SGND as shown below.

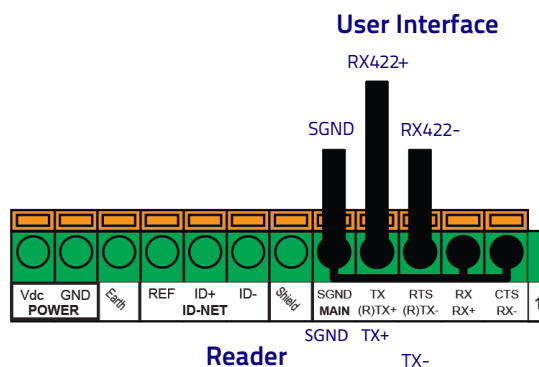

Figure 18 - RS422 Full Duplex Connections Using Only TX Signals to Host

ID-NET Interface

CBX100/500	Description
Shield	Network Cable Shield
ID+	ID-NET Network Data +
ID-	ID-NET Network Data -
REF	Network Reference

ID-NET Cables

The following instructions are referred to Figure 20, Figure 21 and Figure 22.

- The general cable type specifications are: CAT5 twisted pair + additional CAT5 twisted pair, shielded cable AWG 24 (or AWG 22) stranded flexible.
We recommend using DeviceNet cables (drop or trunk type) to the following reference standards:
AN50325 – IEC 62026
UL STYLE 2502 80°C 30V
- Cable Shield MUST be connected to earth ground ONLY at the Master.
- NEVER use ID-NET cable shield as common reference.
- The ID-NET max cable length depends on the baudrate used, (see the Baudrate Table below).
- For Common Power Connections use only 2 wires (ID+ and ID-).
 - DC Voltage Power cable (Vdc – GND) should be handled as a signal cable (i.e. do not put it together with AC cable):
 - Wire dimensioning must be checked in order to avoid voltage drops greater than 0.8 Volts.
 - Cable should lie down as near as possible to the ID-NET cable (avoiding wide loops between them).
- Reader's chassis may be connected to earth.
- Network inside the same building.

Baudrate Table				
Baudrate	125 kbps	250 kbps	500 kbps	1 Mbps
Cable Length	1200 m	900 m	700 m	x ¹

1. Application dependent, contact your Datalogic representative for details.



NOTE: The default ID-NET baudrate is 500 kbps. Lower ID-NET baudrates allow longer cable lengths.

ID-NET Response Time

The following figure shows the response time of the ID-NET network. This time is defined as the period between the Trigger activation and the beginning of data transmission to the Host.

Max ID-NET Response Time

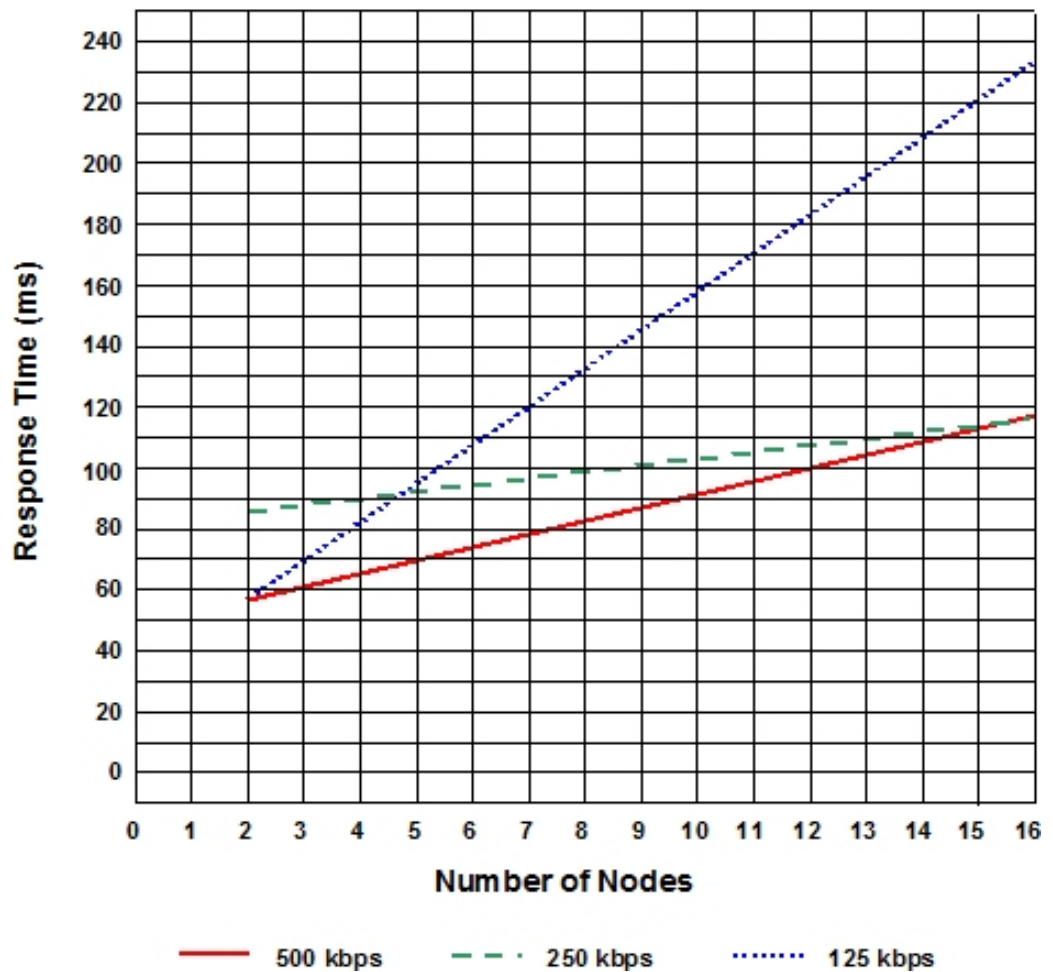

Figure 19 - ID-NET Response Time

Conditions

- ID-NET M/S Synchronized layout
- message length = 50 bytes per node

ID-NET Network Termination

The network must be properly terminated in the first and last reader of the network. This is done by setting the ID-NET Termination Resistance Switch in the CBX100/500 to ON.

ID-NET Connection Diagrams

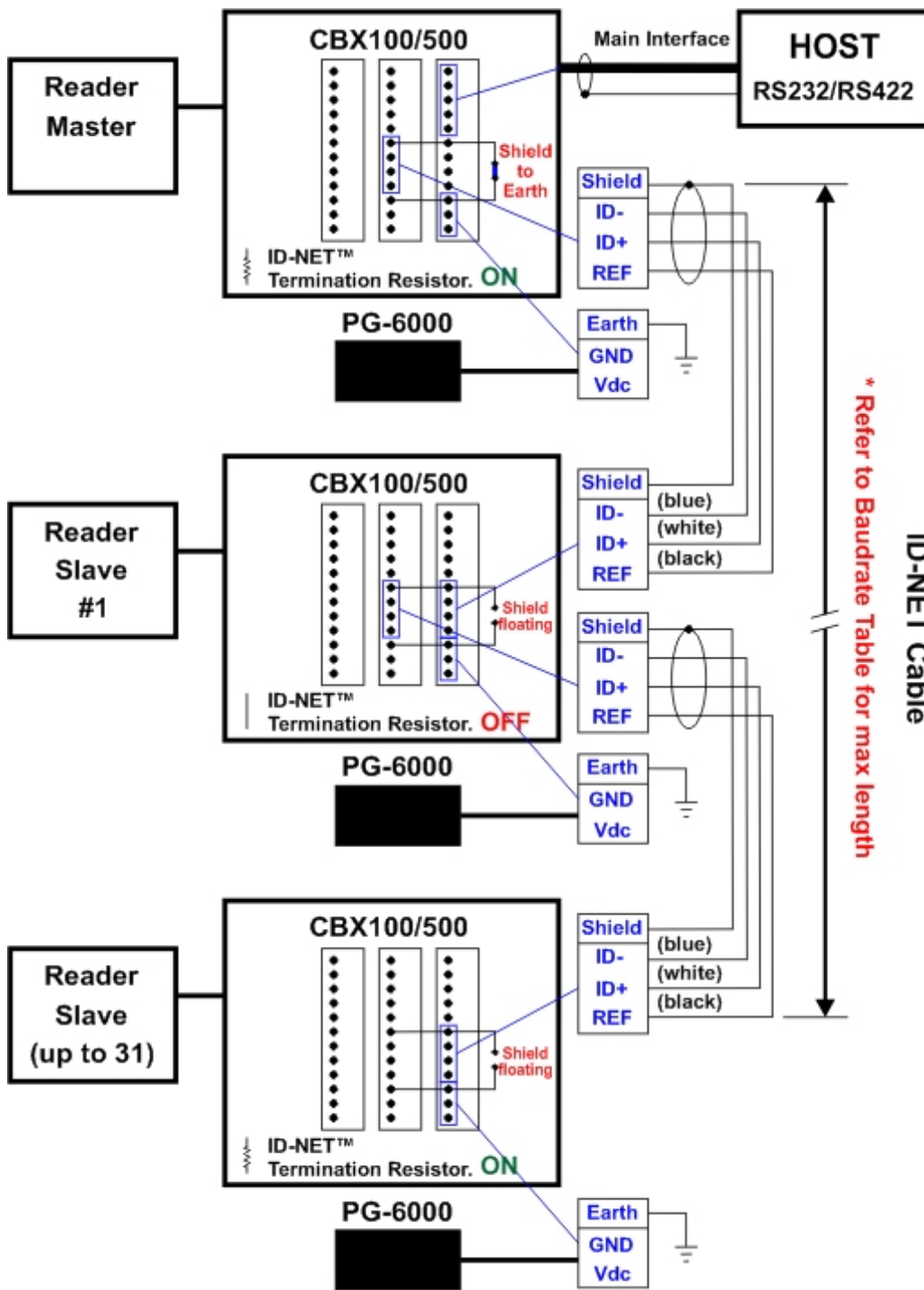

Figure 20 - ID-NET Network Connections with isolated power blocks

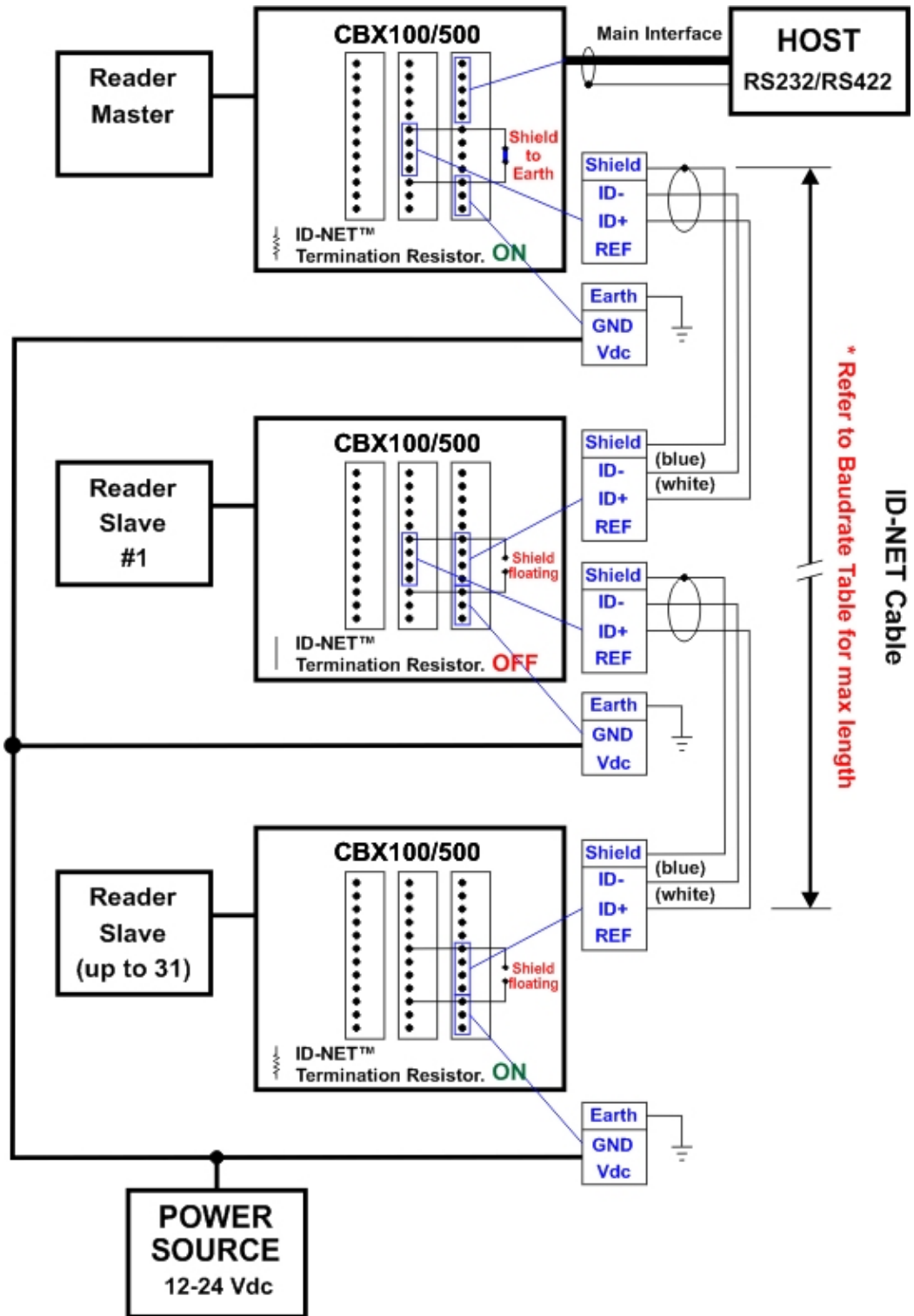

Figure 21 - ID-NET Network Connections with Common Power Branch Network

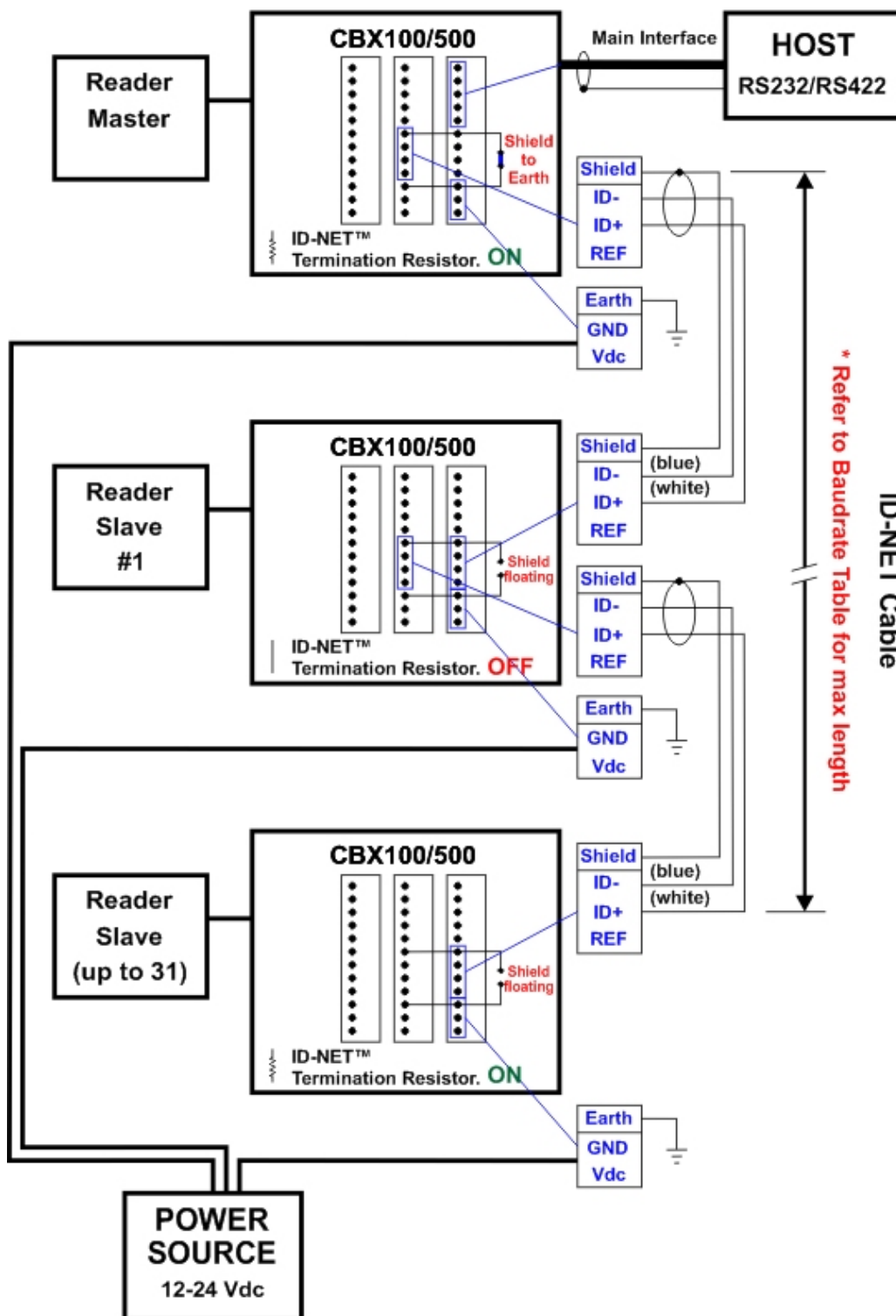

Figure 22 - ID-NET Network Connections with Common Power Star Network

Auxiliary RS232 Interface

The RS232 auxiliary interface is available for Point-to-Point connections. When it is connected to the host computer it allows transmission of code data.

The parameters relative to the aux interface (baud rate, data bits, etc.) can be defined through the Reading Phase step (Channels) in DL.CODE.

The 9-pin female Auxiliary Interface connector inside the CBX is the preferred connector for temporary communication monitoring.

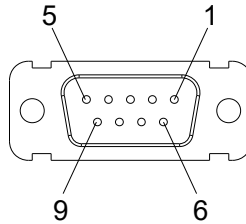
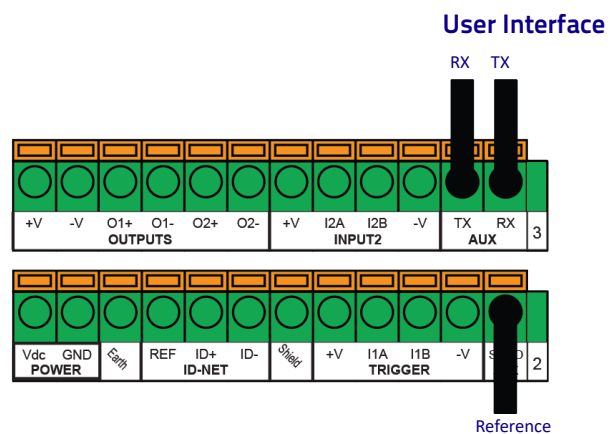

Figure 23 - 9-pin female connector

If permanent system wiring is required, the following pins are used to connect the RS232 auxiliary interface:

CBX100/500	Description
TX	Auxiliary Interface Transmit Data
RX	Auxiliary Interface Receive Data
SGND	Auxiliary Interface Reference



NOTE: Do not connect the Aux Interface to the CBX spring clamp connectors and the 9-pin connector simultaneously.

Inputs

There are two optocoupled polarity insensitive inputs available on the reader: Input 1 (External Trigger) and Input 2, a generic input:

The External Trigger can be used in One Shot Mode or in Phase Mode. Its main functions are:

- acquisition trigger in One Shot Mode
- reading phase-ON/reading phase-OFF command in Phase Mode

The main functions of the general purpose Input 2 are:

- second external trigger in Phase Mode
- match code storage command when the Match Code option is enabled

The electrical features of both inputs are:

$V_{AB} = 30 \text{ Vdc max.}$

$I_{IN} = 10 \text{ mA (reader) + 12 mA (CBX) max.}$

The active state of these inputs are selected in software.

An anti-disturbance filter, by default, is implemented in software on both inputs. The value can be changed through the software parameter Debounce Filter. See the Help On Line page of the Reading Phase step (Inputs) in DL.CODE for further details on these parameters.

These inputs are optocoupled and can be driven by both NPN and PNP type commands.



NOTE: Polarity insensitive inputs assure full functionality even if pins A and B are exchanged.

The connections are indicated in the following diagrams:

CBX100/500	Description
+V	Power Source - External Trigger
I1A	External Trigger A (polarity insensitive)
I1B	External Trigger B (polarity insensitive)
-V	Power Reference - External Trigger

The yellow Trigger LED (Figure 2, 3) is on when the active state of the External Trigger corresponds to ON.

External Trigger Input Connections Using Blade Power



CAUTION: Power from the Vdc/GND spring clamps is available directly to the Input Device on the +V/-V spring clamps, and does not pass through the Power Switch (ON/OFF) inside the CBX. Disconnect the power supply when working inside the CBX.

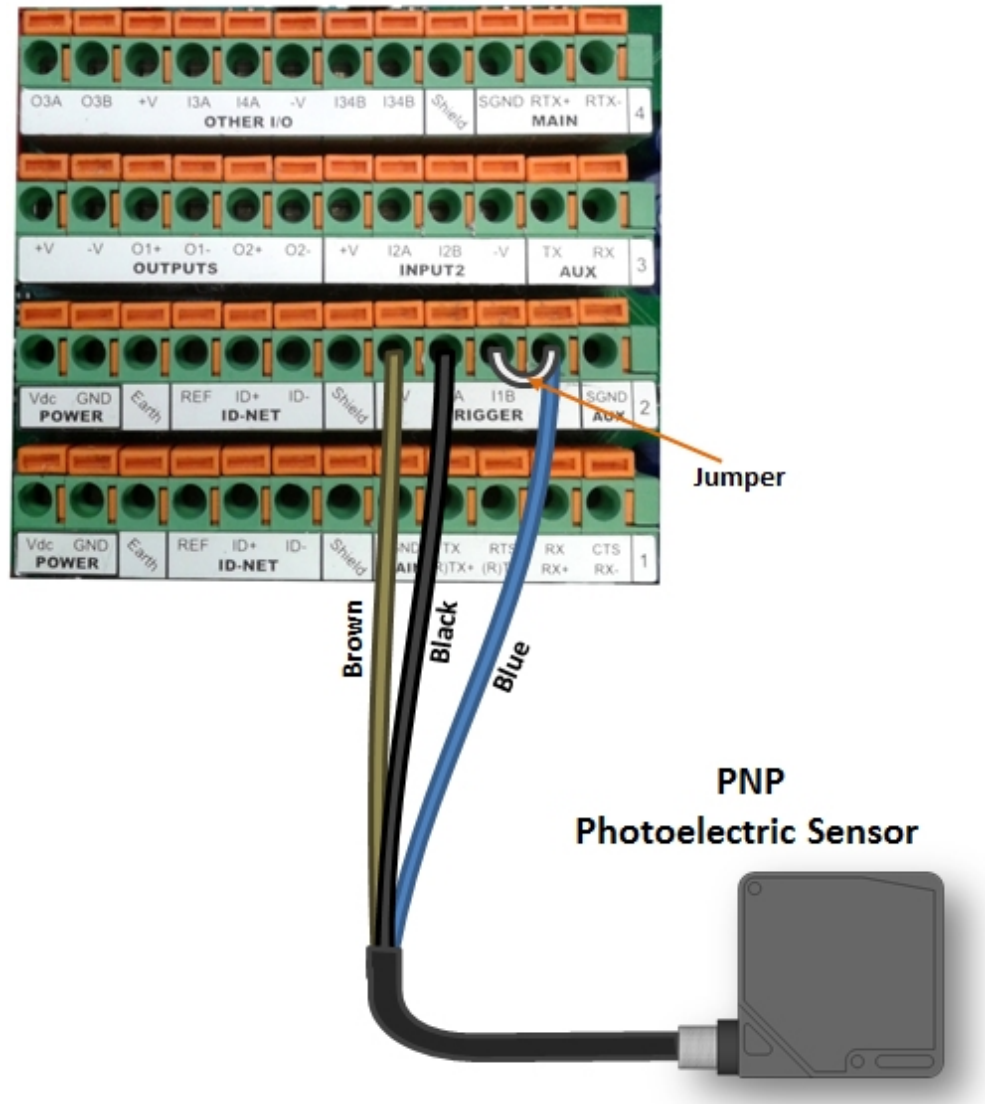

Figure 24 - PNP External Trigger Using Blade Power

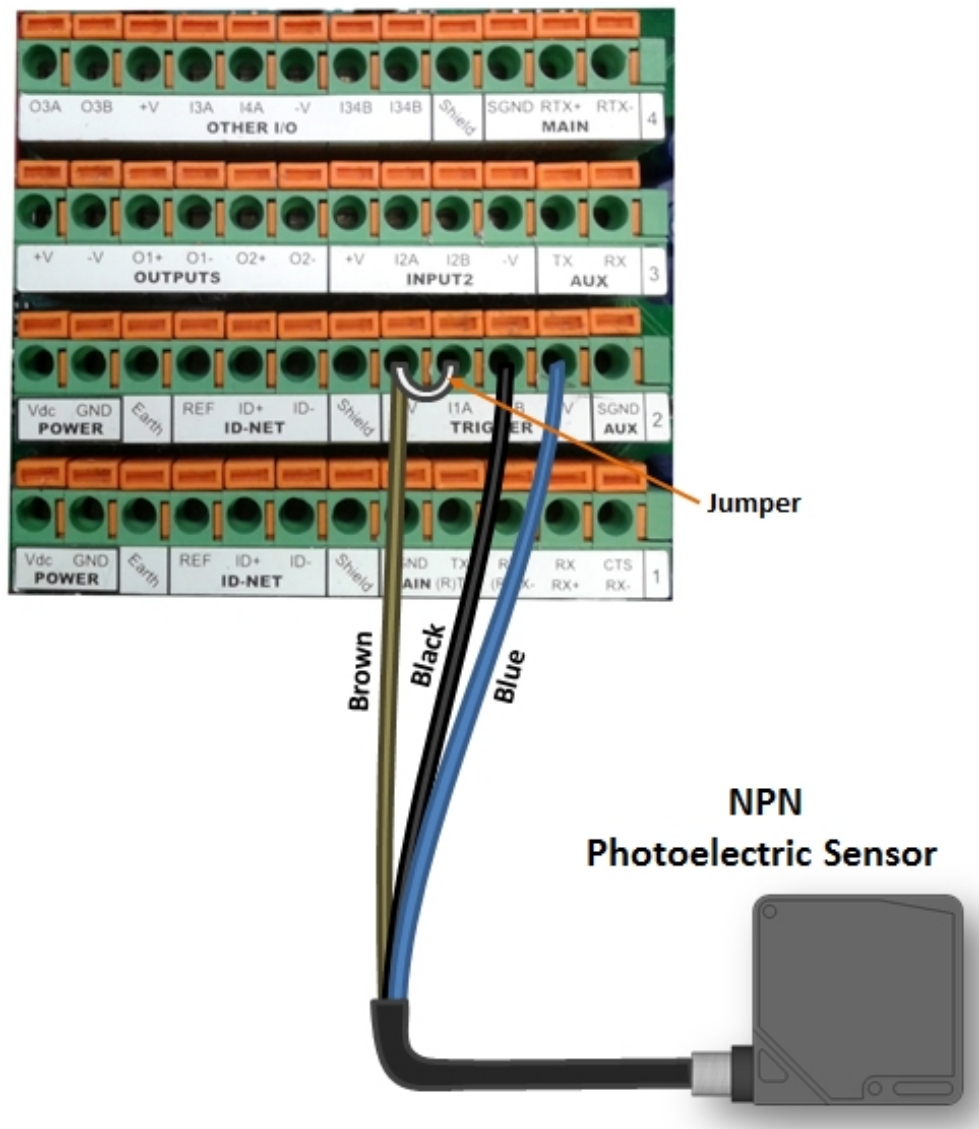

Figure 25 - NPN External Trigger Using Blade Power

External Trigger Input Connections Using External Power

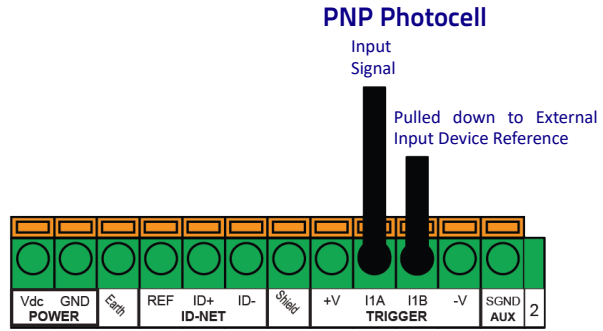

Figure 26 - PNP External Trigger Using External Power

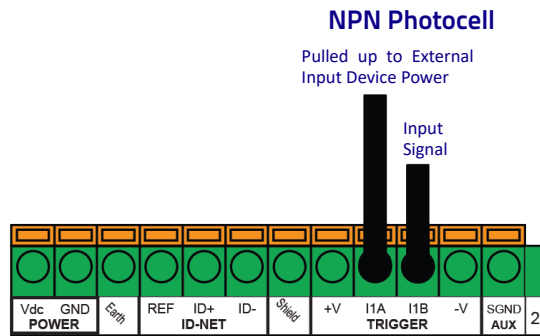

Figure 27 - NPN External Trigger Using External Power

CBX100/500	Description
+V	Power Source - External Trigger
I2A	Input 2 A (polarity insensitive)
I2B	Input 2 B (polarity insensitive)
-V	Power Reference - External Trigger

Input 2 Connections Using Blade Power



CAUTION: Power from the Vdc/GND spring clamps is available directly to the Input Device on the +V/-V spring clamps, and does not pass through the Power Switch (ON/OFF) inside the CBX. Disconnect the power supply when working inside the CBX.

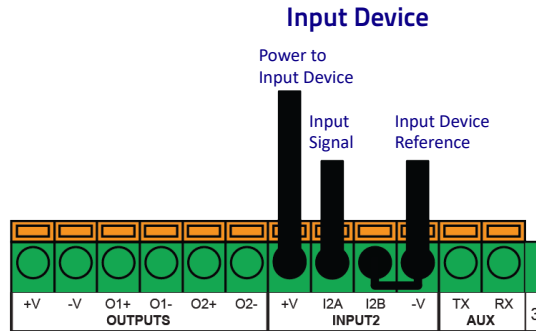

Figure 28 - PNP Input 2 Using Blade Power

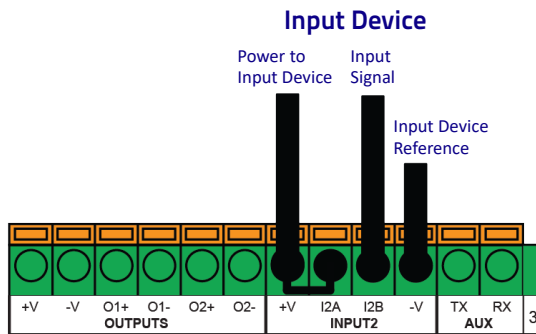

Figure 29 - NPN Input 2 Using Blade Power

Input 2 Connections Using External Power

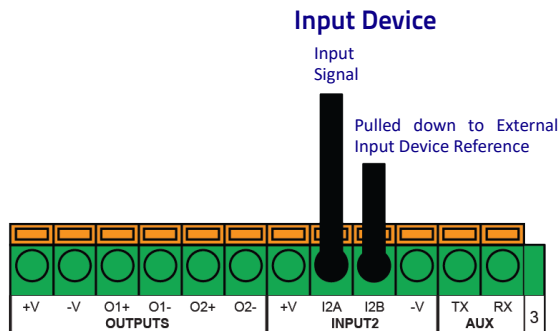

Figure 30 - PNP Input 2 Using External Power

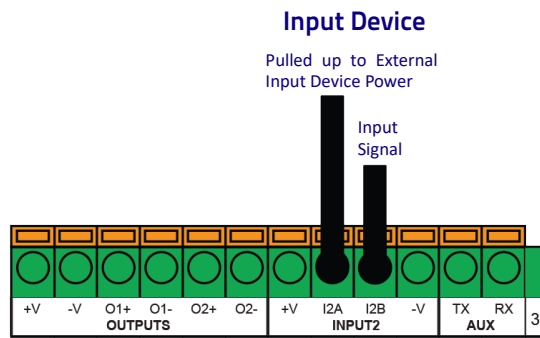

Figure 31 - NPN Input 2 Using External Power

Input 3 Connections (CBX500 Only)

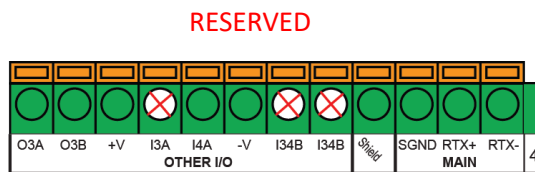

Figure 32 - Input 3 Using External Power



CAUTION: Do not connect to I3A or I34B signals, they are reserved.

Outputs



CAUTION: When Outputs 1 and 2 are connected through the CBX connection box, they become opto-isolated and polarity sensitive and acquire the electrical characteristics listed below. To function correctly, they require setting the Output Line Type configuration parameters to NPN for the respective output. The hardware connection to the CBX can be either NPN or PNP.

Three general purpose outputs are available and their meaning can be defined by the user. They are typically used either to signal the data collection result or to control an external lighting system.

CBX100/500	Description
+V	Power Source - Outputs
O1+	Output 1 + opto-isolated and polarity sensitive
O1-	Output 1 - opto-isolated and polarity sensitive
O2+	Output 2 + opto-isolated and polarity sensitive
O2-	Output 2 - opto-isolated and polarity sensitive
-V	Power Reference - Outputs

The electrical features of the outputs are the following:

Outputs 1 and 2
$V_{CE} = 30 \text{ Vdc max.}$
$I_{CE} = 40 \text{ mA continuous max.; } 130 \text{ mA pulsed max.}$
$V_{CE \text{ saturation}} = 1 \text{ Vdc max. @ } 10 \text{ mA}$
$P_D = 90 \text{ mW Max. @ } 50 \text{ }^\circ\text{C ambient temp.}$

By default, Output 1 is associated with the No Read event, which activates when the code(s) signaled by the external trigger are not decoded, and Output 2 is associated with the Good Read event, which activates when all the selected codes are correctly decoded.

The output signals are fully programmable being determined by the configured Activation/Deactivation events, Deactivation Timeout or a combination of the two. Refer to the DL.CODE parameters Help On Line for further details.

Output 1 and 2 Connections Using Blade Power



CAUTION: Power from the Vdc/GND spring clamps is available directly to the Output Device on the +V/-V spring clamps, and does not pass through the Power Switch (ON/OFF) inside the CBX. Disconnect the power supply when working inside the CBX.

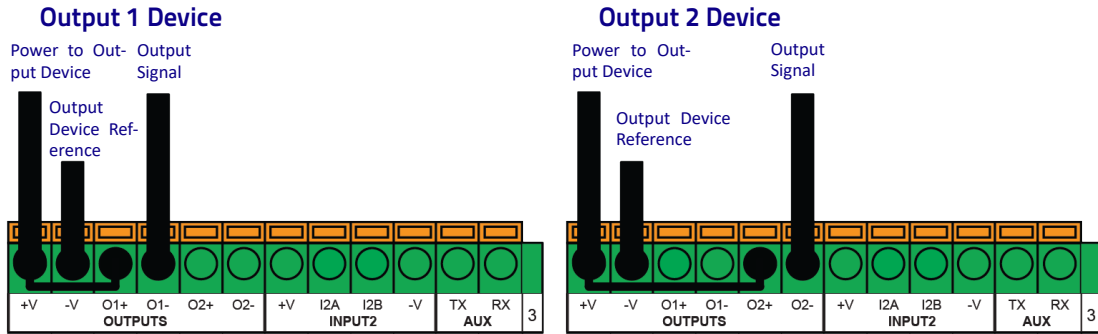

Figure 33 - PNP/Open Emitter Output Using Blade Power

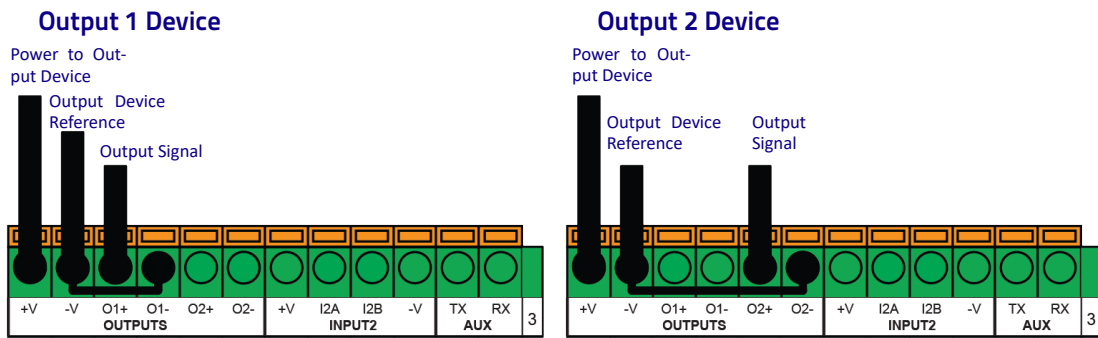

Figure 34 - NPN/Open Collector Output Using Blade Power

Output 1 and 2 Connections Using External Power

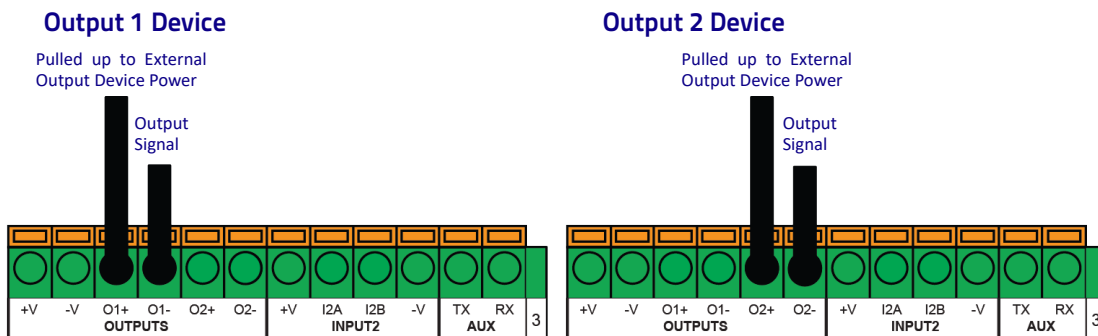

Figure 35 - PNP/Open Emitter Output Using External Power

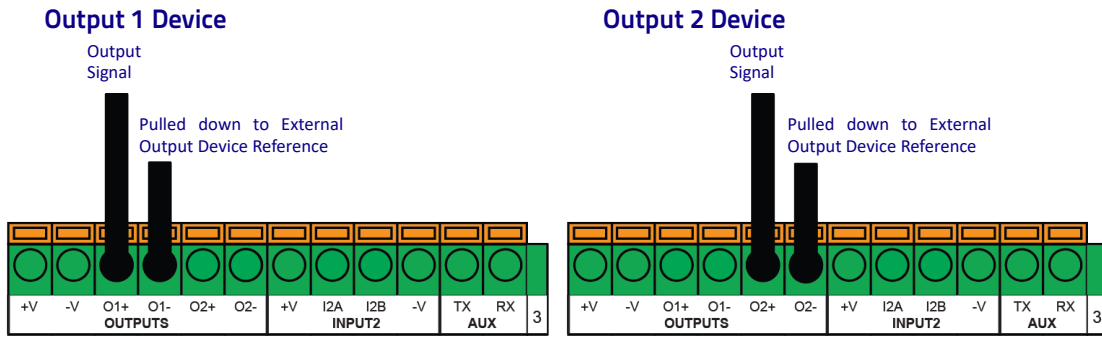

Figure 36 - NPN/Open Collector Output Using External Power

Output 3 is **not opto-isolated** but can be assigned to the same events. By default it is not assigned to any event. The CBX500 must be used to connect this output.



NOTE: For Output 3, set the Line Type configuration parameter according to the hardware connection to the CBX: NPN, PNP or Push-Pull.

On-Board Ethernet Interface

The on-board Ethernet Interface can be used for TCP/IP communication with a remote or local host computer by connecting the reader to either a LAN or directly to a host PC. There is no need to use a crossover adapter since Blade incorporates an auto-cross function.

A **CAB-ETH-M0x** cable can be used to connect to a LAN.

On the Blade on-board Ethernet interface the following communication channels are available:

- TCP Client
- TCP Server
- UDP Channel
- FTP Client

The following Fieldbus protocols are also available over the on-board Ethernet interface:

- Modbus TCP Client

For further details refer to the Help On Line page of the Reading Phase step (Channels) and (Fieldbuses) in DL.CODE.

User Interface - Serial Host

The following table contains the pinout for standard RS232 PC Host interface. For other user interface types please refer to their own manual.

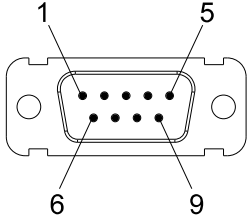
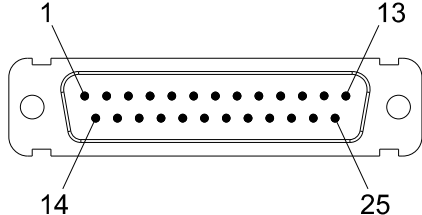
RS232 PC-side Connections			
 <p>9-pin male connector</p>		 <p>25-pin male connector</p>	
Pin	Name	Pin	Name
2	RX	3	RX
3	TX	2	TX
5	GND	7	GND

CHAPTER 5

TYPICAL LAYOUTS

The following typical layouts refer to system hardware configurations. However, they also require the correct setup of the software configuration parameters. Dotted lines in the figures refer to optional hardware configurations within the particular layout.



NOTE: All software configurations are made through DL.CODE which connects to the reader through the on-board Ethernet interface.



NOTE: DL.CODE now supports several different multi device configuration types using the PASS-THROUGH configuration. In particular this feature allows MULTIDATA ID-NET network configurations to be made. Master/Slave SYNCHRONIZED ID-NET network configurations are also configurable as before.



NOTE: The Master/Slave Role is only significant for the Internal ID-NET Network. If your layout doesn't use the ID-NET network then the device's Role is not significant and can be ignored.

ETHERNET CONNECTION

The Ethernet connection is possible in two different layouts.

In a Point-to-Point layout the reader is connected to a local host by using a CAB-ETH-M0x cable. There is no need to use a crossover adapter since Blade incorporates an autocross function.

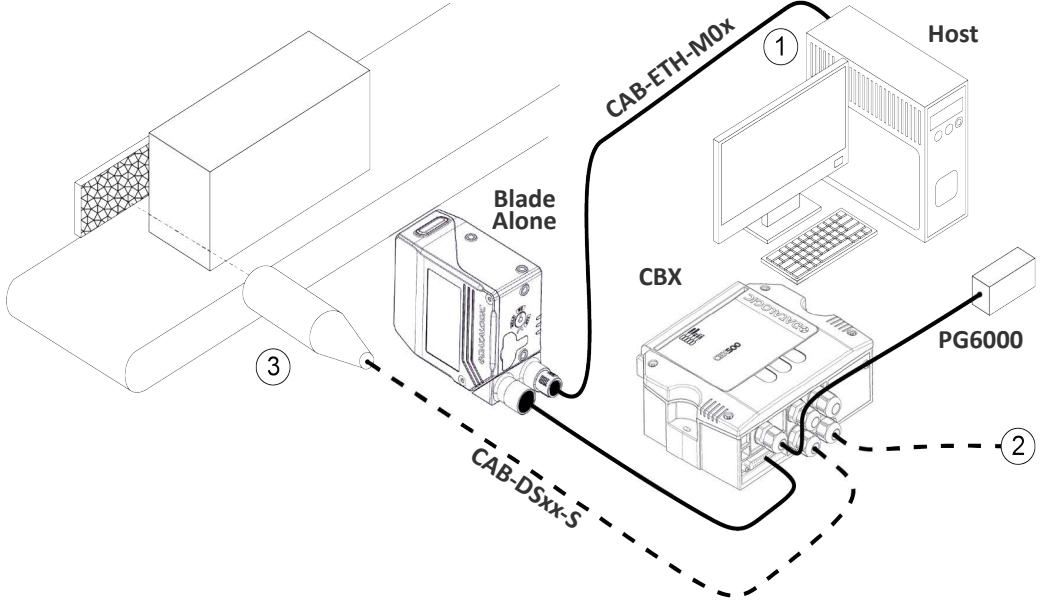

- 1 - Ethernet Interface
- 2 - Auxiliary Serial Interface (RS232 - Data Monitor)
- 3 - External Trigger (for Phase Mode. See "Sensors" on page 141. for more details)

Figure 37 - Ethernet Point-to-Point Layout

All devices always support multiple output channels (i.e. for data monitoring).

When using a Local Area Network (LAN), one or more Blade readers can be connected to the network by using **CAB-ETH-M0x** cables:

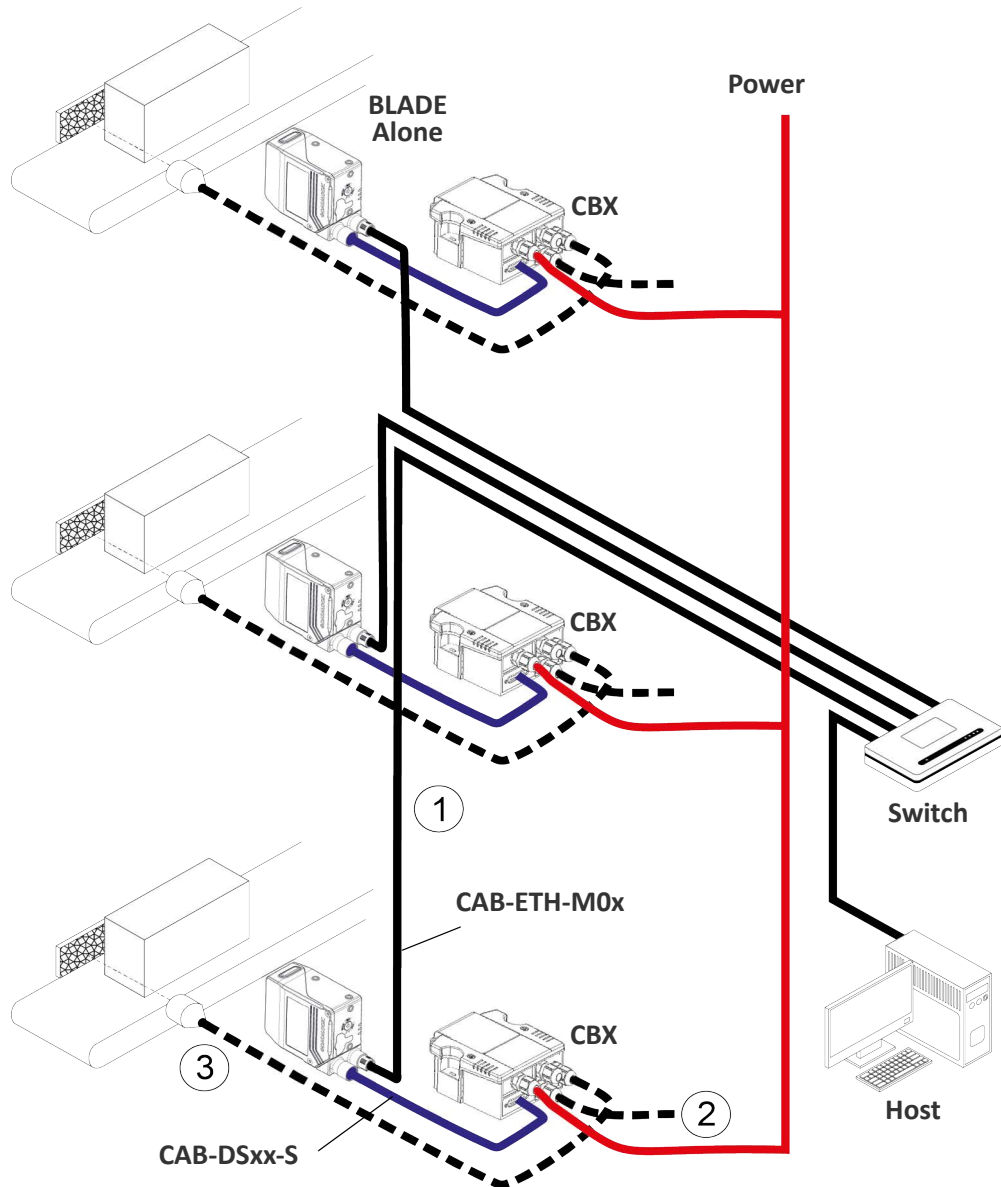

- 1 - Ethernet Interface
- 2 - Auxiliary Serial Interface (RS232 - Data Monitor)
- 3 - External Trigger (for Phase Mode. See "Sensors" on page 141. for more details)

Figure 38 - Ethernet Network Layout

SERIAL CONNECTION

In this layout the data is transmitted to the Host on the main serial interface. The Ethernet interface can be used for reader configuration by connecting a laptop computer running DL.CODE.

Data can be transmitted on the RS232 auxiliary interface independently from the main interface selection to monitor data.

When Phase Mode operating mode is used, the reader can be activated by an External Trigger (for example a pulse from a photoelectric sensor) when the object enters its reading zone.

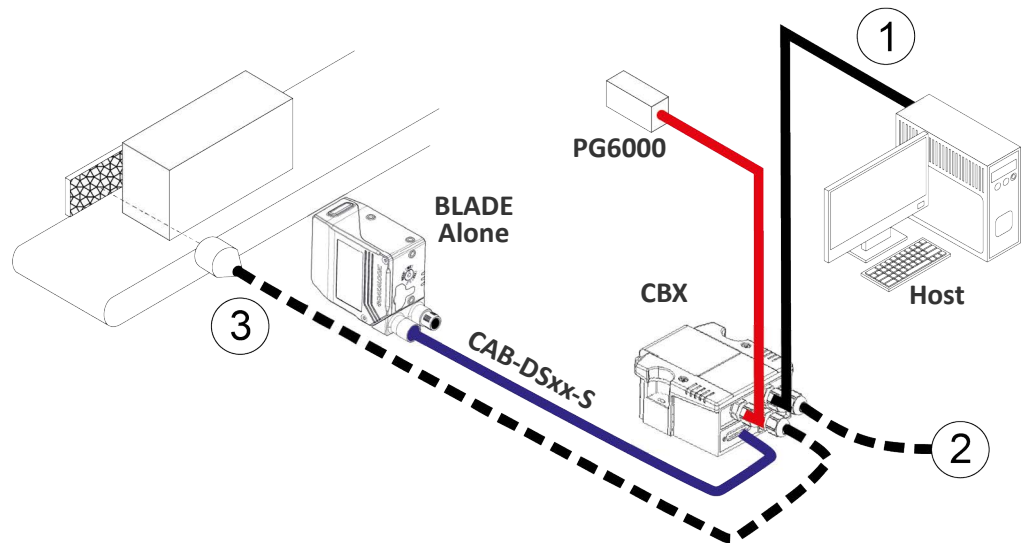

- 1 - Main Serial Interface (RS232 or RS422 Full-Duplex)
- 2 - Auxiliary Serial Interface (RS232 - Data Monitor)
- 3 - External Trigger (for Phase Mode. See "Sensors" on page 141. for more details)

Figure 39 - Serial Interface Point-to-Point Layout

All devices always support multiple output channels (i.e. for data monitoring).

PASS-THROUGH

The pass-through layout allows each device **working Alone**, to collect data from one or more pass-through input channels and send this data plus its own on one or more different output channels.

In this way independent devices can be connected together in combinations to create multi device networks. Many devices reading independently can send their messages through a common output channel which instead of being directed at a Host can be collected by another device on its pass-through input channel and sent to a Host on a different output channel.

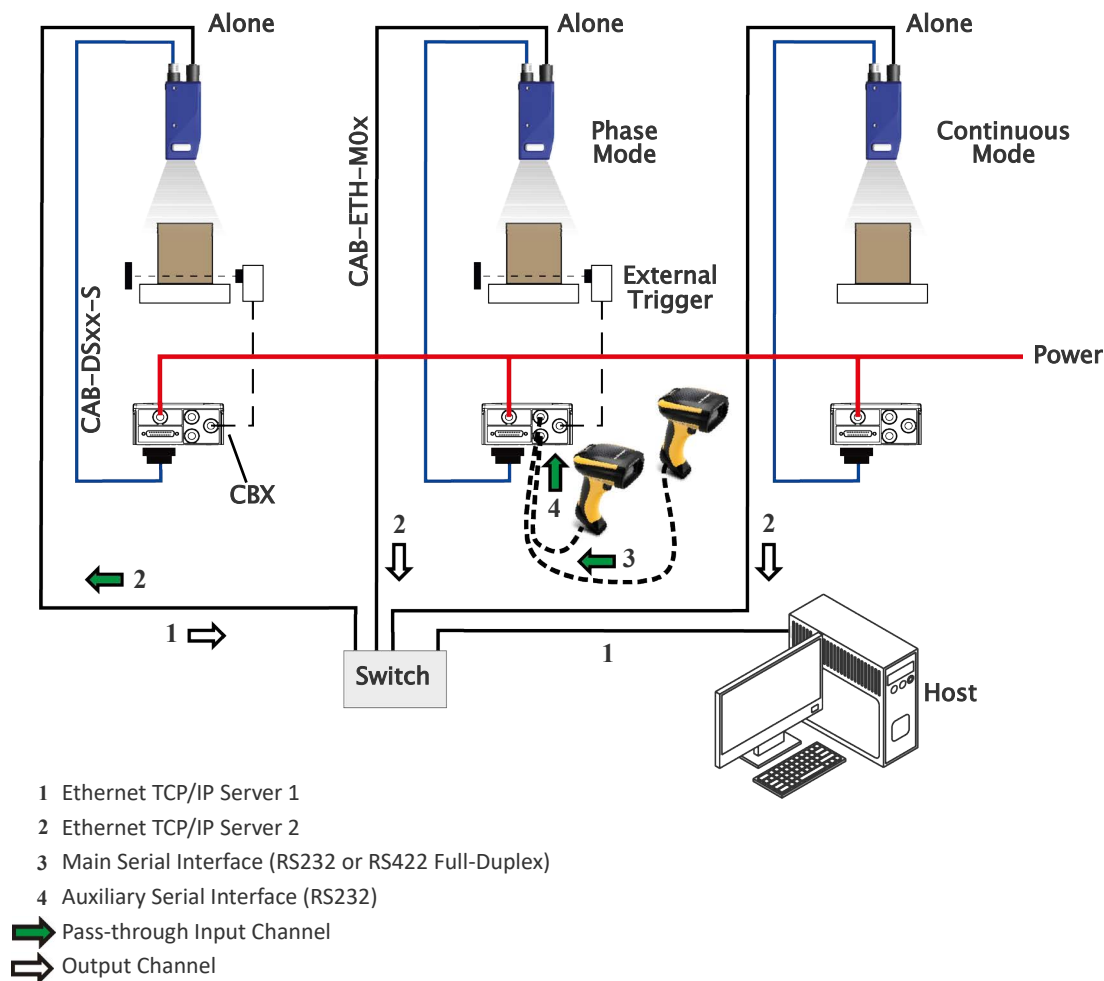

Figure 40 - Pass-Through Layout

In a Pass-through layout each device supports multiple pass-through configurations to accept input from different devices on different channels (i.e. middle reader above). However, readers are not required to have a pass-through configuration if they don't need to receive data from an input channel (i.e. right reader above). The overall data collection device always has at least one pass-through configuration to collect the input data from the other devices and send it to the Host (i.e. left reader above).

All devices always support multiple output channels (i.e. for data monitoring).

In a Pass-through layout each device can have a different operating mode: Continuous, One Shot, Phase Mode, etc.

ID-NET

The ID-NET network is a built-in high-speed interface dedicated for high-speed reader interconnection. ID-NET is in addition to the Main and Auxiliary serial interfaces.

The following network configurations are available:

- Single station – multiple readers: "[ID-NET Synchronized Network](#)" on page 58
- Multiple stations – single reader: "[ID-NET Multidata Network \(Pass-Through\)](#)" on page 62

ID-NET Synchronized Network

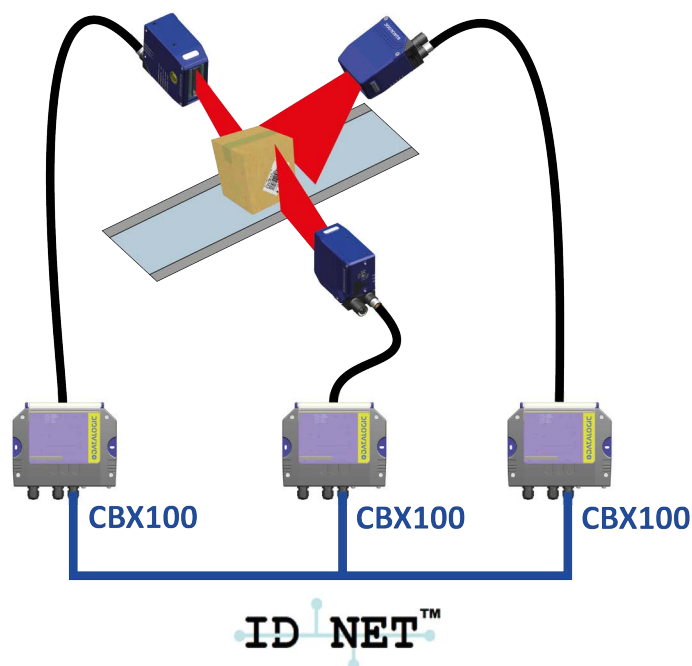

ID-NET interface allows local connection of multiple readers reading different sides of the same target. All readers share a single presence sensor and activate/deactivate simultaneously.

At the end of each reading phase a single data message is transmitted to the host. Thanks to ID-NET, data communication among readers is highly efficient so that an immediate result will be available.

When the device is **working Synchronized**, the ID-NET connection is used to collect data from several readers to build a multi-point or a multi-sided reading system; there can be one Master and up to 31 Slaves connected together.

The Slave readers are connected together using the ID-NET interface. Every slave reader must have an ID-NET address in the range 1-31.

The Master reader is also connected to the Host on one of its communication channels. In the following examples the RS232/RS422 main serial interface is used.

For a Master/Slave Synchronized layout the External Trigger signal is unique to the system; there is a single reading phase and a single message from the Master reader to the Host computer. **It is not necessary to bring the External Trigger signal to all the readers.**

In the Master/Slave Synchronized layout the Master operating mode can only be set to Phase Mode.

The Main and ID-NET interfaces are connected as shown in the following figures.

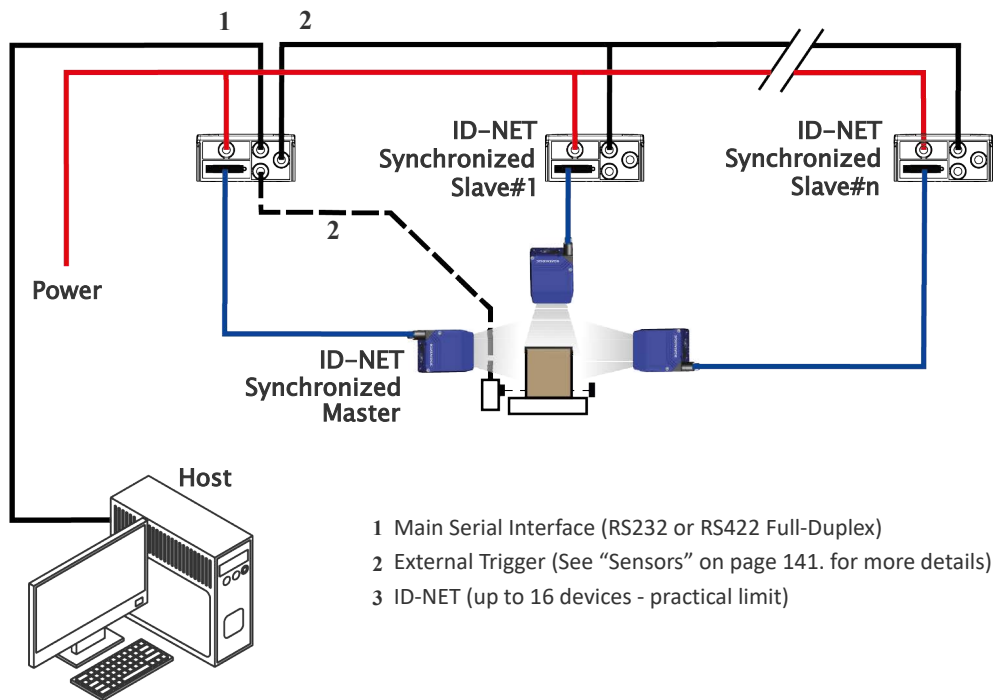

Figure 41 - ID-NET Synchronized Layout

The Master reader can be connected to the CBX series connection box with the advantage of the Backup and Restore configuration function (CBX + BM100 module). All devices always support multiple output channels (i.e. for data monitoring).

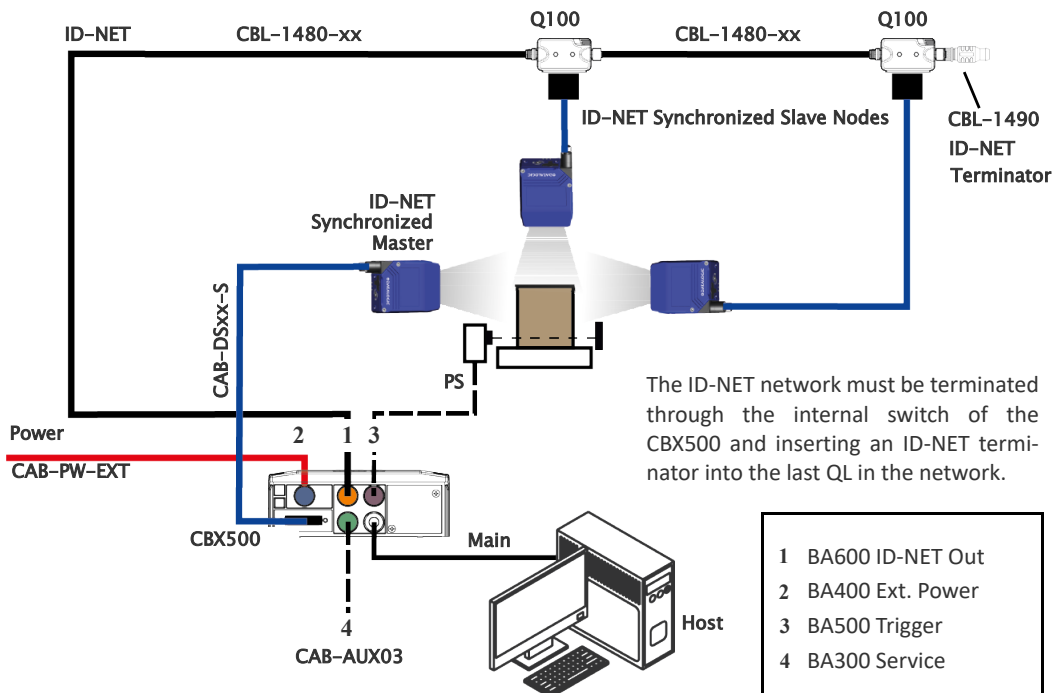

Figure 42 - ID-NET Synchronized Layout Blade Master with CBX500 + Blade Slaves with QL100

If the Backup and Restore function is not required, then a QL300 can be used to connect the master reader.

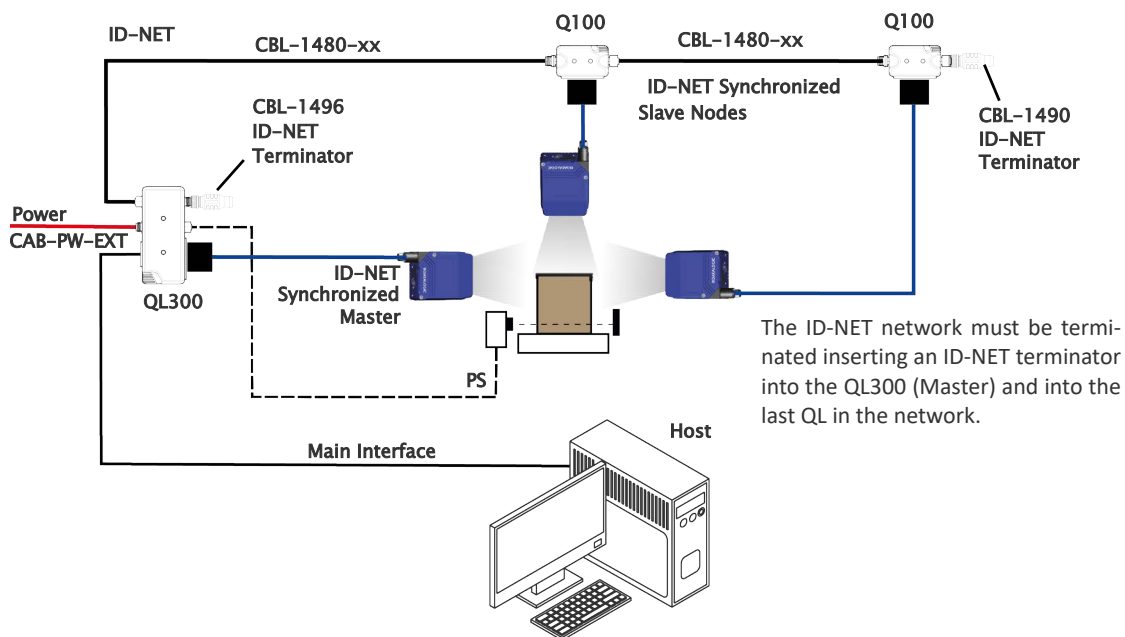

Figure 43 - ID-NET Synchronized Layout Blade Master with QL300+ Blade Slaves with QL100

The same configuration can be made to a Host using the on-board Ethernet interface to the Master. The TCP/IP Ethernet and ID-NET interfaces are connected as shown in the figure below.

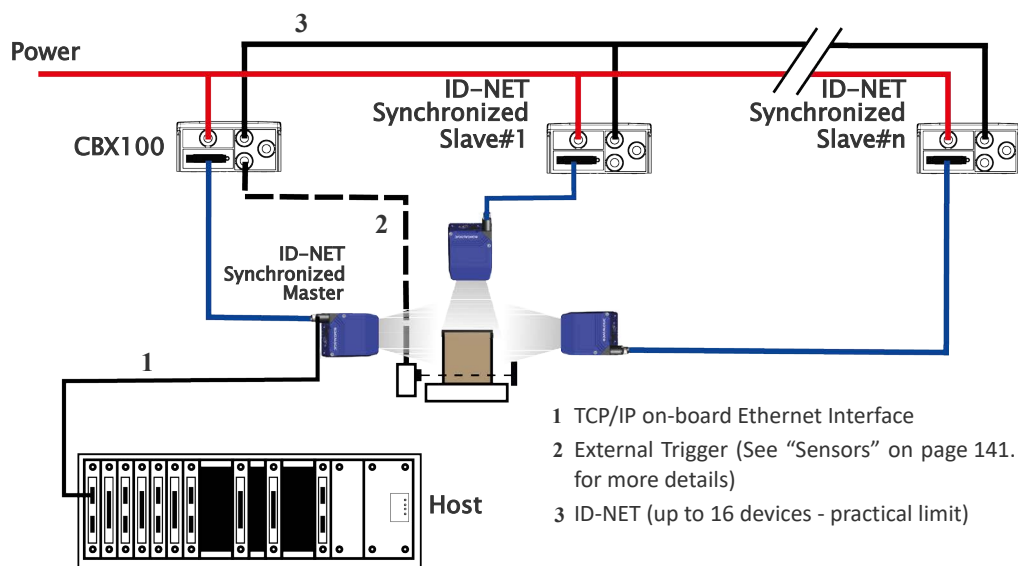

Figure 44 - ID-NET Synchronized Layout with Master on-board TCP/IP Ethernet Interface to Host

Alternatively, the Master reader can communicate to the Host as a Slave node on a Fieldbus network. This requires using an accessory Fieldbus interface board installed inside the CBX500 connection box. System configuration can be accomplished through the Ethernet interface of each individual reader using the DL.CODE configuration program.

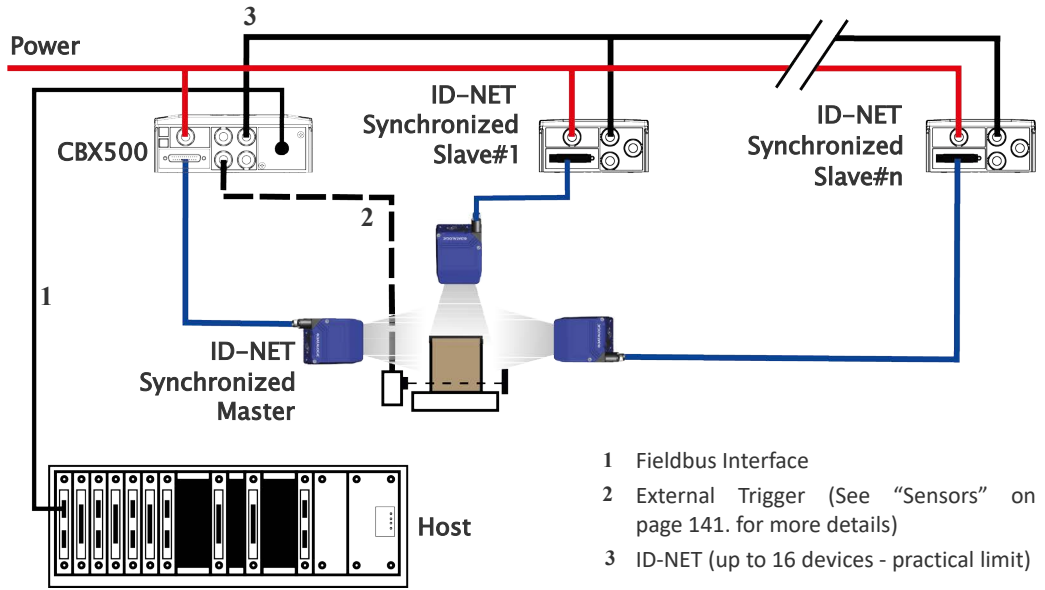
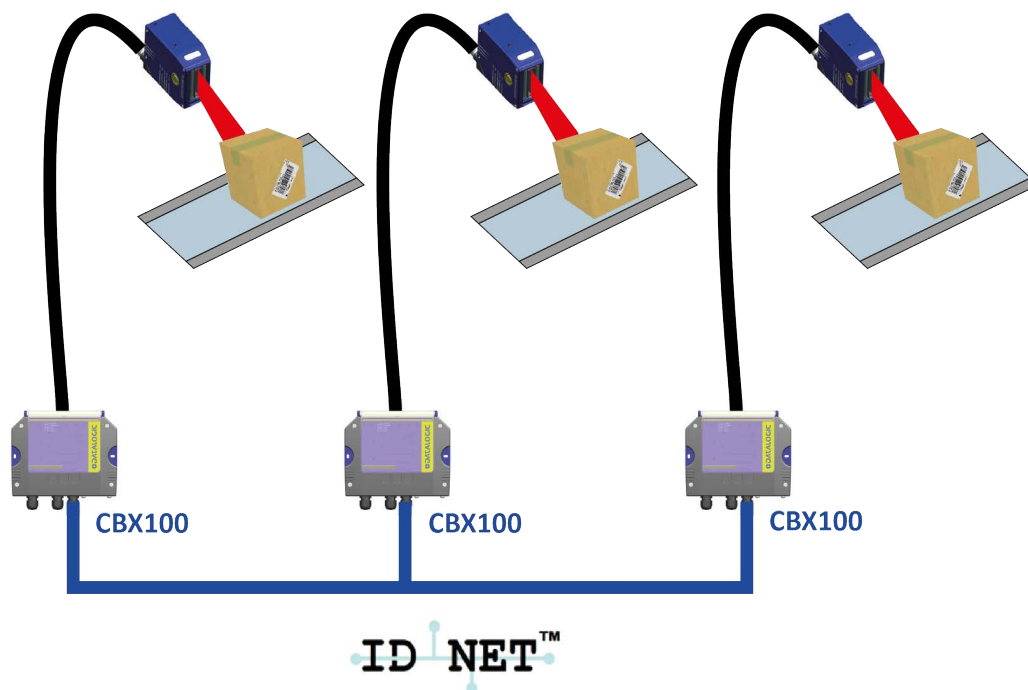

Figure 45 - ID-NET Synchronized Layout with Master CBX500 Fieldbus Interface to Host

ID-NET Multidata Network (Pass-Through)



ID-NET interface allows connection of readers reading objects placed on independent conveyors. All readers are typically located far away from each other and they can have different operating modes from each other.

At the end of each reading phase, each reader transmits its own data message to the host. Thanks to ID-NET, data collection among readers is accomplished at a high speed without the need of an external multiplexing device. This leads to an overall cost reduction and to simple system wiring.

A special case of the pass-through layout allows each Slave device **working Alone**, to collect data from one or more pass-through input channels and send this data plus its own on the ID-NET output channel to the Master.

The Slave readers are connected together using the ID-NET interface. Every Slave reader must have an ID-NET address in the range 1-31.

The Master collects the data from its pass-through ID-NET input channel and sends it to the Host on a different output channel.

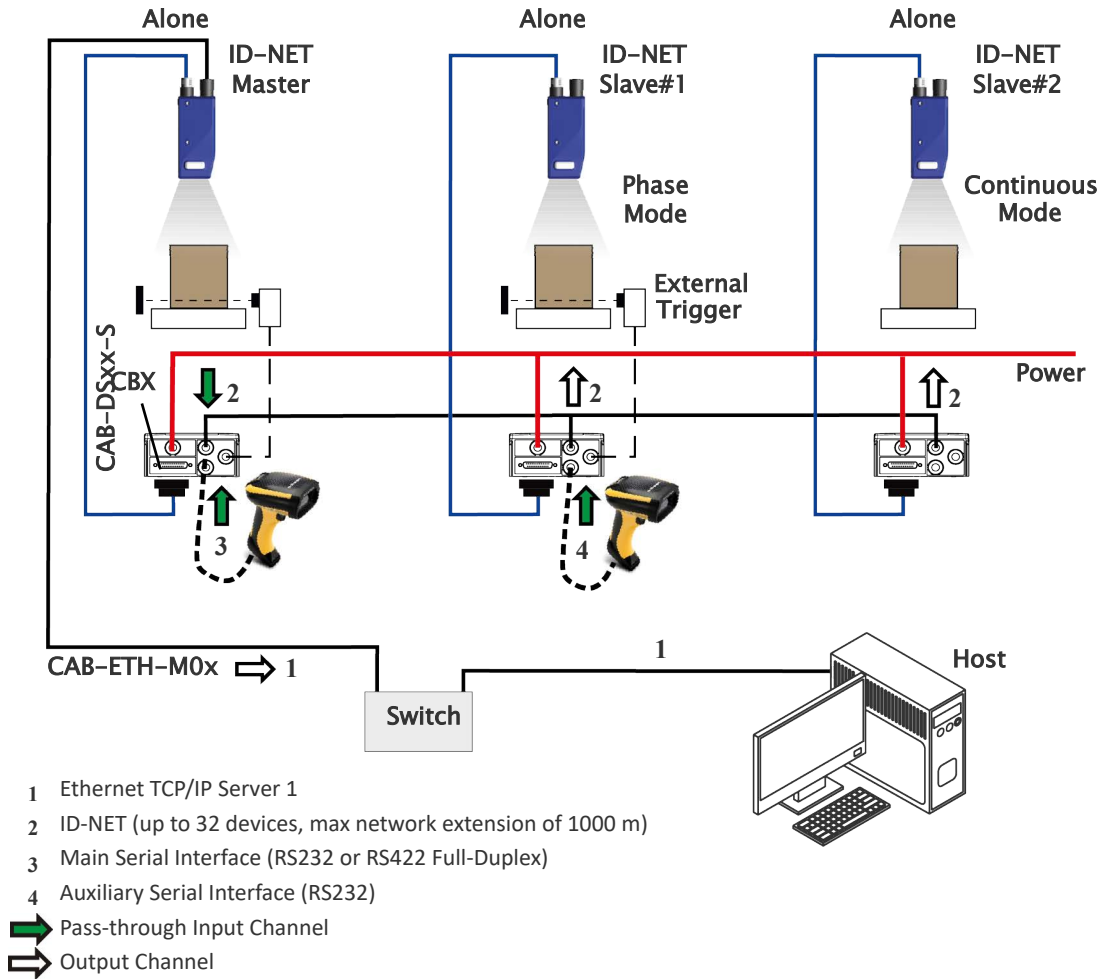

Figure 46 - ID-NET Multidata Layout (Pass-through)

In a Pass-through layout each device supports multiple pass-through configurations to accept input from different devices on different channels (i.e. Master reader above). However, ID-NET Slave readers are not required to have a pass-through configuration if they don't need to receive data from an input channel (i.e. right reader above). The ID-NET Master always has at least one pass-through configuration to collect the ID-NET Slaves data and send it to the Host.



NOTE: Slave devices cannot receive data from a pass-through ID-NET input channel and Master devices cannot send data on an ID-NET output channel.

All devices always support multiple output channels (i.e. for data monitoring).

In a Pass-through layout each device can have a different operating mode: Continuous, One Shot, Phase Mode, etc.

FIELD BUS

Profinet-IO

More than one Blade (xxx-x3xx) models scanner is chained together in the PROFINET-IO network by using an ETH CABLE M12-M12 cable. The first scanner in the chain is connected to a Certified PROFINET-IO Switch or PLC using a CAB-ETH-M0x cable. The last scanner has a protection cap to cover the unused port. Every scanner must have its own unique Station Name (see Profinet-IO Line Parameters in Help On Line).

Power connections can be made using the CS-A1-02 or AS-I accessory power cables to the power source. The CS-A1-02 cable also allows the External Trigger Input to be connected to a presence sensor.

However, it is possible to connect Blade in all the topologies permitted by the Profinet standard

Ethernet-IP

More than one Blade (xxx-x2xx) models scanner is chained together in the Ethernet-IP network by using an ETH CABLE M12-M12 cable. The first scanner in the chain is connected to a Certified Ethernet-IP Switch or PLC using a CAB-ETH-M0x cable. The last scanner has a protection cap to cover the unused port. Every scanner must have its own unique IP Address (see Ethernet-IP Line Parameters in Help On Line).

Power connections can be made using the CS-A1-02 or AS-I accessory power cables to the power source. The CS-A1-02 cable also allows the External Trigger Input to be connected to a presence sensor.

However, it is possible to connect Blade in all the topologies permitted by the Ethernet-IP standard.

Fieldbus accessories for Ethernet models

Blade Ethernet models are compatible with CBX500 based accessory Fieldbus interface boards.

In this layout a single reader functions as a Slave node on a Fieldbus network. The data is transmitted to the Host through an accessory Fieldbus interface board installed inside the CBX500 connection box.

Reader configuration can be accomplished through the Ethernet interface using the DL.CODE configuration program.

Data can be transmitted on the RS232 auxiliary interface independently from the Fieldbus interface selection to monitor data.

When One Shot or Phase Mode operating mode is used, the reader can be activated by an External Trigger (photoelectric sensor) when the object enters its reading zone.

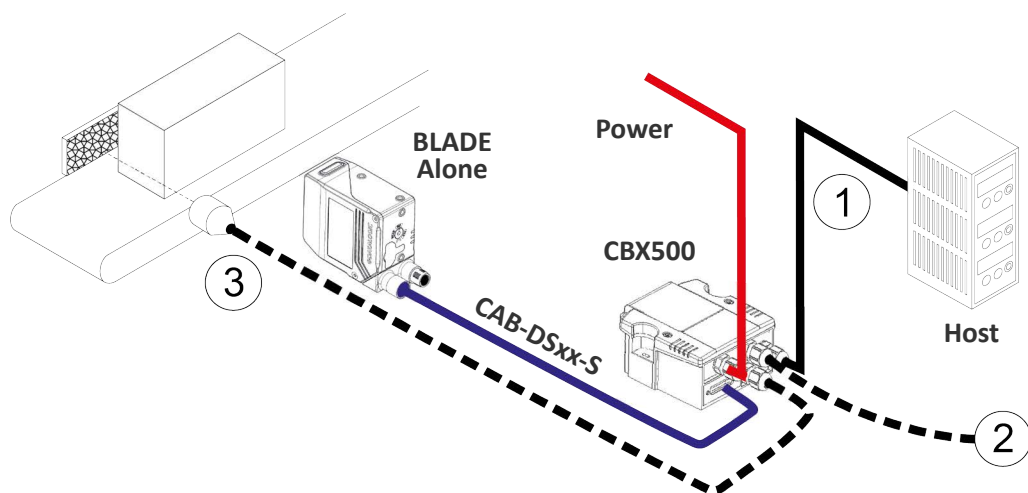

- 1 - Fieldbus Interface (Profibus, DeviceNet, etc.)
- 2 - Auxiliary Serial Interface (RS232 - Data Monitor)
- 3 - External Trigger (for Phase Mode. See "Sensors" on page 141. for more details)

Figure 47 - Fieldbus Interface Point-to-Point Layout

All devices always support multiple output channels (i.e. for data monitoring).

CHAPTER 6

SET UP

CONFIGURATION USING WEB DISCOVERY

Devices can be discovered via web interface. To do this, from either the Host PC or configuration PC connected to the network, open your browser and go to <http://data-logic.local/>.

This page shows all devices available in the network:

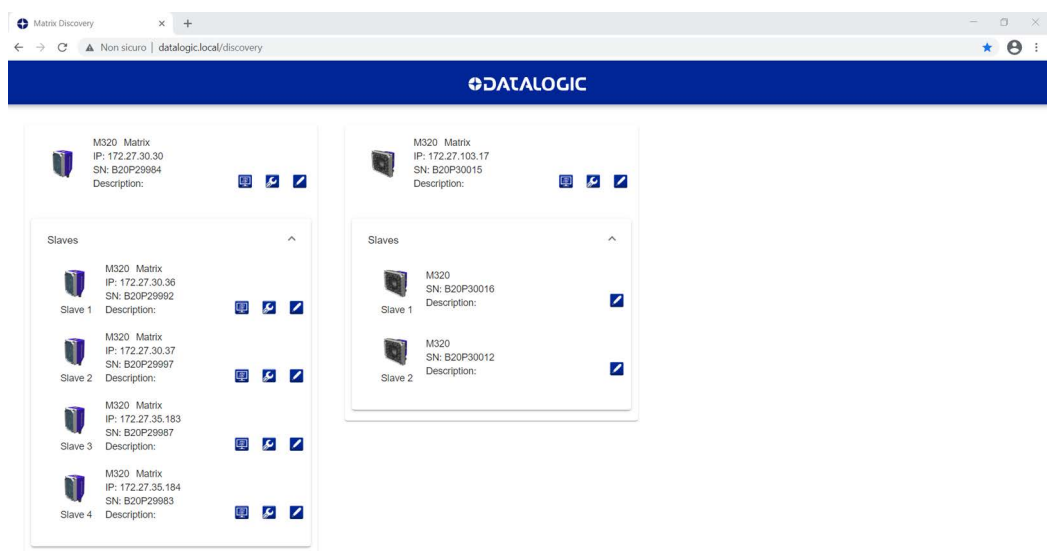





Click on the wrench icon and input the correct IP Address settings (from network administrator) and optional Device Description for each reader.

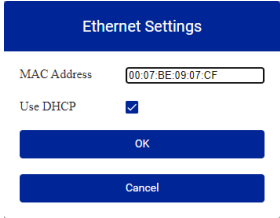
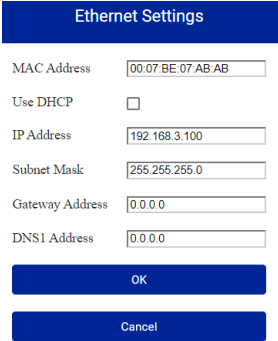

NOTE: At least one device must be reachable from the user PC. For example, if there are several subnetworks, at least one device must be in the same subnetwork of the PC.

The following functions are available for each discovered device:

	<p>Web Monitor is a remote monitoring tool provided to visualize a device in its run-time environment. You can access it from the DL.CODE Task area, from the Discovery page, or from your browser by inputting the IP address of the reader. The reader must be available on the LAN.</p> <p>This works on major browsers (also on smartphones and tablets), which support HTML5.</p> <p>Refer to the DL.CODE User's Manual for more information on this remote monitoring tool.</p>
	<p>Display and configure the Ethernet settings, as shown in the figures below (left: device in DHCP mode¹; right: device in Static mode):</p> <div style="display: flex; justify-content: space-around;"> <div data-bbox="652 728 932 945">  <p>Ethernet Settings</p> <p>MAC Address: 00:07:BE:09:07:CF</p> <p>Use DHCP: <input checked="" type="checkbox"/></p> <p>OK</p> <p>Cancel</p> </div> <div data-bbox="997 595 1276 934">  <p>Ethernet Settings</p> <p>MAC Address: 00:07:BE:07:AB:AB</p> <p>Use DHCP: <input type="checkbox"/></p> <p>IP Address: 192.168.3.100</p> <p>Subnet Mask: 255.255.255.0</p> <p>Gateway Address: 0.0.0.0</p> <p>DNS1 Address: 0.0.0.0</p> <p>OK</p> <p>Cancel</p> </div> </div>
	<p>Set the device description. In case of Slave devices, this button is only available if the corresponding Master device is reachable.</p> <div data-bbox="825 1052 1104 1223">  <p>Device Description</p> <p>Device Description: <input type="text"/></p> <p>OK</p> <p>Cancel</p> </div>

1. Use DHCP addressing only if the network is connected to a DHCP Server.

X-PRESS HUMAN MACHINE INTERFACE

X-PRESS is the intuitive Human Machine Interface designed to improve ease of installation and maintenance.



NOTE: During the reader startup (reset or restart phase), all the LEDs blink for one second.

In normal operating mode the colors and meaning of the five LEDs are illustrated below:

- **READY** (green): indicates the device is ready to operate.
- **BACKUP** (green): indicates that a valid Backup is present on the SD card.
- **TRIGGER** (yellow): indicates the status of the reading phase.
- **COM** (yellow): indicates active communication.
- **STATUS** (red): blinks together with Ready led to indicate an active diagnostic message.

Whereas the single push button gives immediate access to the following relevant functions:

- "Aim" on page 70
- "Test Mode" on page 70
- "Learn" on page 71
- "Init" on page 71

X-PRESS™ Interface Details

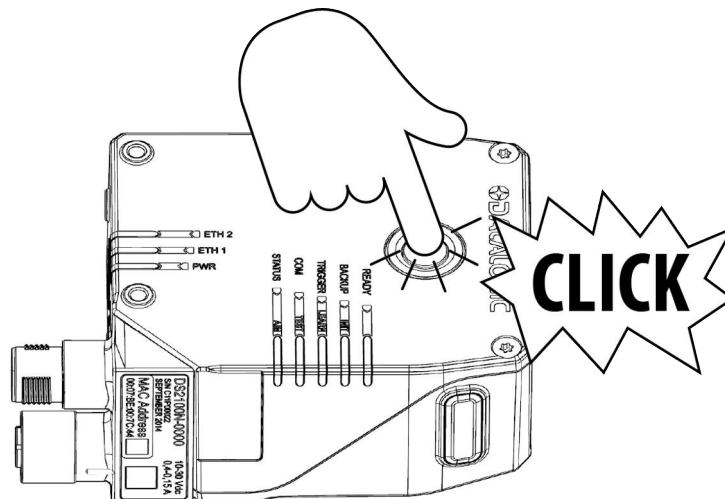

Figure 48 - HMI X-PRESS™ Interface Details

	NORMAL OPERATION	X-PRESS CONFIGURATION
1	Ready	
2	Backup	Init
3	Trigger	Learn
4	COM	Test
5	Status	Aim
6	Push button	

X-PRESS Functions

Quick access to the functions is provided by an easy procedure using the push button:



Button procedures

- **X-Press enter:** Keep pressed the button for more than 1 second.
- **Change function:** Short press **less than 1 second**.
- **Enter function:** Keep pressed the button for more than 1 second.

Once button is pressed, the cycle of LEDs activation is as follows:

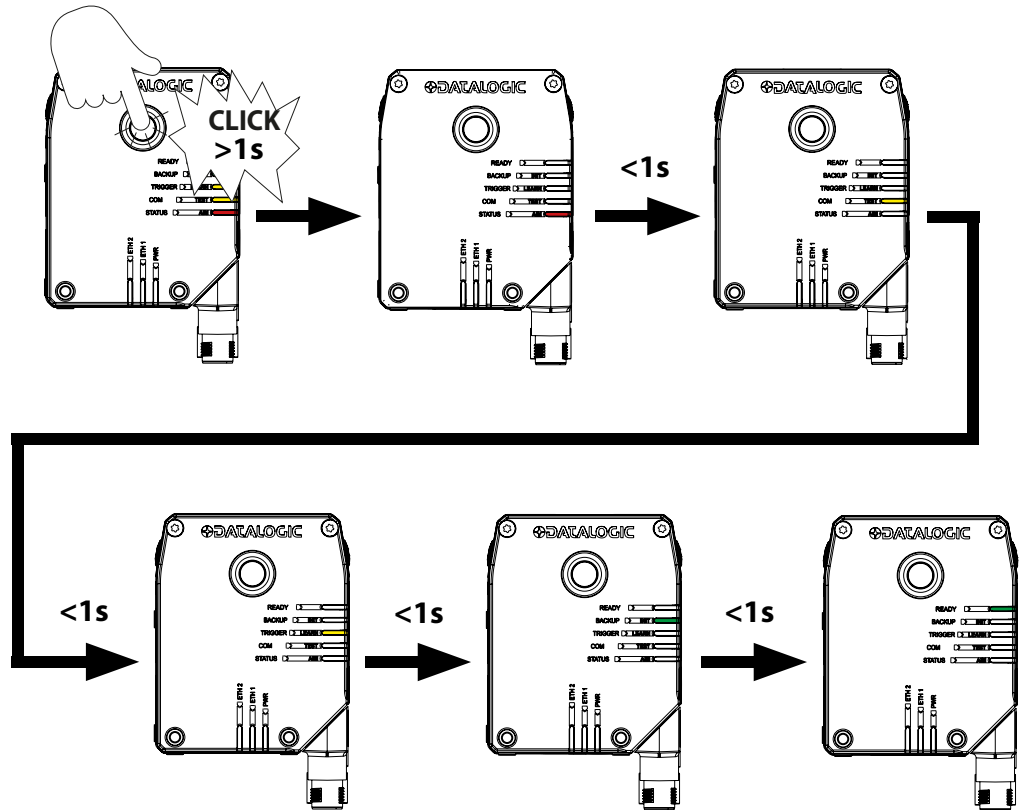

Aim

Once entered, all the code symbologies are enabled, and the device starts reading continuously.

Place a code in front of the reader and check the reading results using the Visual Feedback LEDs to easily verify the exact position of the reading area and aim the reader accordingly.

Test Mode

Test Mode with Bar-Graph visualization to check static reading performance.

Once entered, the Bar-Graph on the five LEDs is activated and if the reader starts reading codes the Bar-Graph shows the Good Read Rate.



To exit the Test, press the X-PRESS push button once.



NOTE: By default, the Test exits automatically after three minutes.

The Bar-Graph has the following meaning:

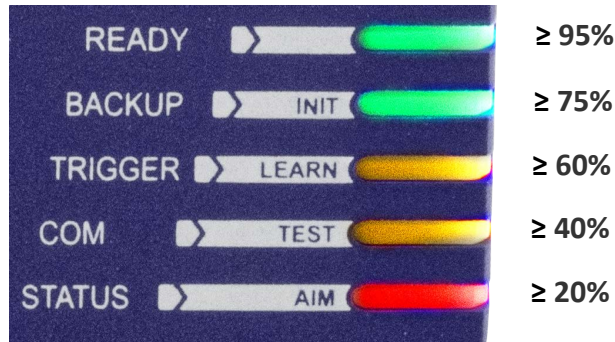

In case of No Read condition, only the STATUS LED (red) is on and blinks.

Learn

Learn to self-detect and auto-configure for reading an unknown barcode (by type and length). Only one symbology type can be saved using this method. Performing Autolearn on a second symbology will overwrite the first one.

Init

Init to forcibly formatting the SD Card possibly inserted, and execute a backup on it (see “Backup and Restore Through Micro SD Card” on page 118)

Diagnostic Indication

The “STATUS” (red) and “READY” LED (green) blink simultaneously to signal the presence of an error. Diagnostic message transmission on interfaces can be enabled to provide details about specific error conditions. See the Diagnostic Error Conditions chart in the Diagnostic page of the DL.CODE Monitor.

	LED	STATUS
	Ready	Blink
	Backup	
	Trigger	
	COM	
	Status	Blink

CHAPTER 7

READING FEATURES

FOV CALCULATION

Use the data in the following table to calculate the FOV of the reader, referring to Figure 49 and the formula below.

d_0	View Angle Horizontal	View Angle Vertical
40 mm	48°	3.1°

The viewing angle has a tolerance of $\pm 1^\circ$ depending on the reading distance.

$$FOV_x = 2 [(d + d_0) * \tan (\alpha_x/2)]$$

where:

FOV_x = horizontal or vertical FOV

α_x = horizontal, vertical or diagonal viewing angles.

d = reading distance (in mm) from window surface to code surface

d_0 = offset (in mm) from center of lens to external window surface

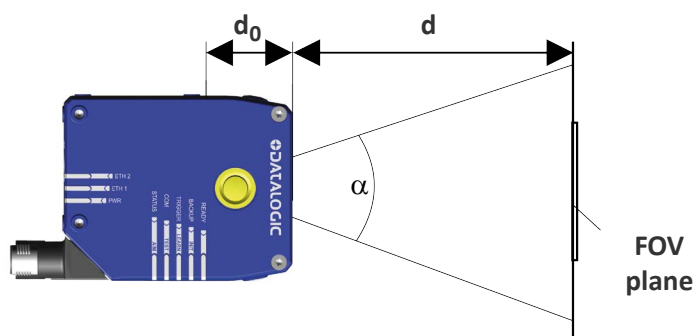

Figure 49 - Reading Distance References

For example:

	$d= 50$ mm	$d= 300$ mm	$d= 600$ mm
H FOV	80	303	570
V FOV	5	18	35



NOTE: This calculation refers to the maximum obtainable Field of View of the reader. The actual reading area depends on code resolution, symbology and reading conditions. See the following Reading Diagrams for details.

READING DIAGRAMMS

The following reading diagrams are to be considered as references and are given for typical performance at 25°C using high quality grade A symbols: Code 128 (1D code) from the Test Charts provided with the reader.

Blade 100 - 2x0x

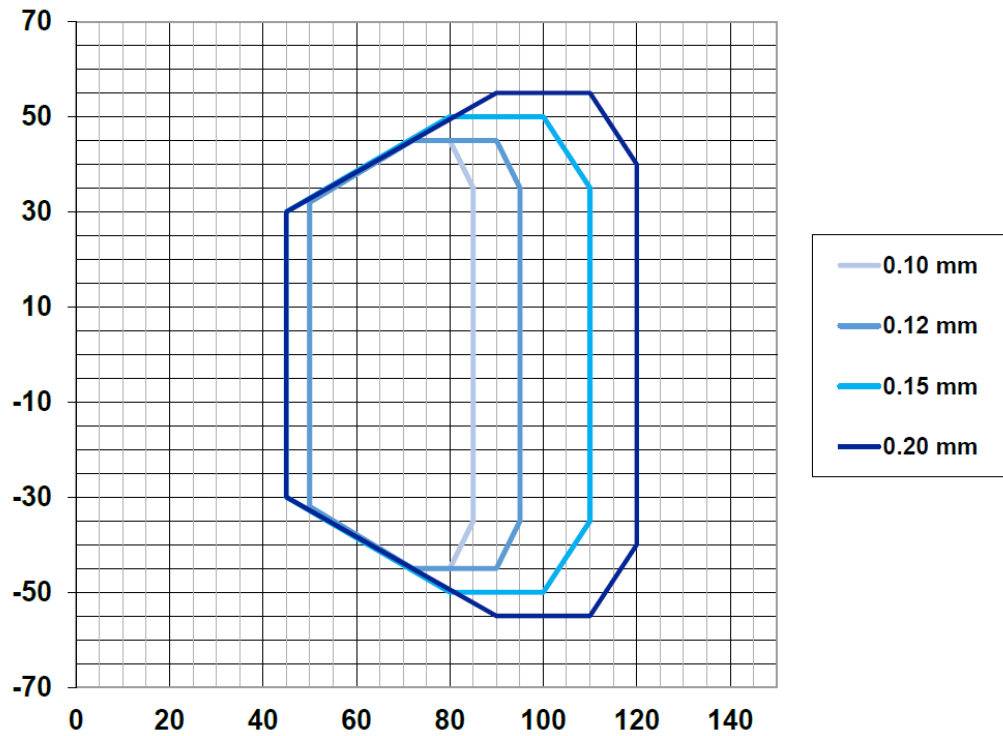

Conditions	
Hardware Settings	
Code Symbology	Code 128
Tilt Angle	0°
Pitch Angle	0°
Skew Angle	15°
Software Parameters	
Exposure Time*	75 μs
Gain*	10
HDR*	Enabled

* Default settings

Blade 100 - 1x0x

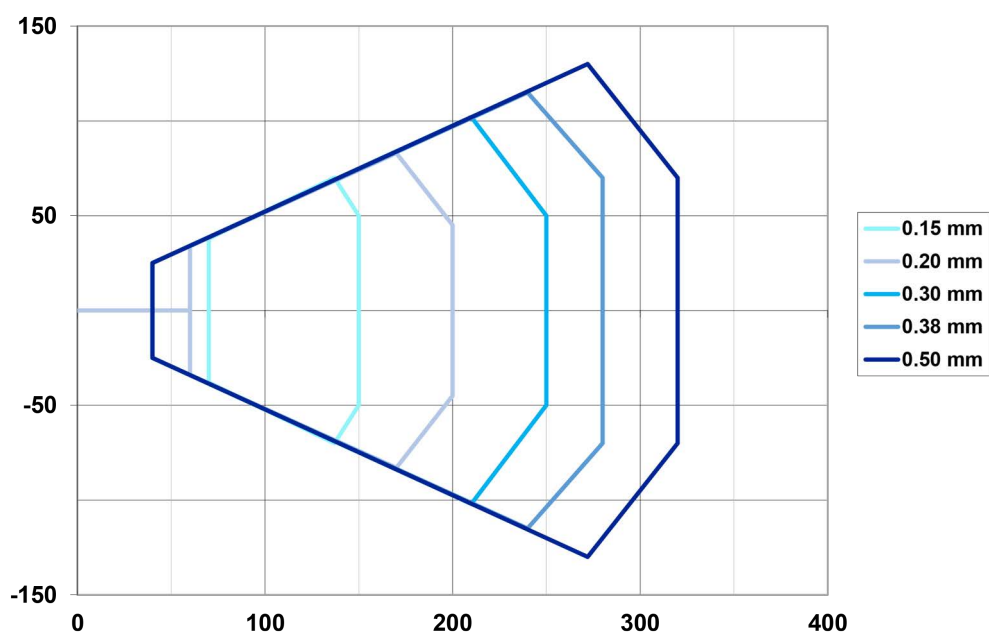

Conditions	
Hardware Settings	
Code Symbology	Code 128
Tilt Angle	0°
Pitch Angle	0°
Skew Angle	15°
Software Parameters	
Exposure Time*	85 μs
Gain*	14
HDR*	Enabled

* Default settings

Blade 200 - xx0x - focus=Near

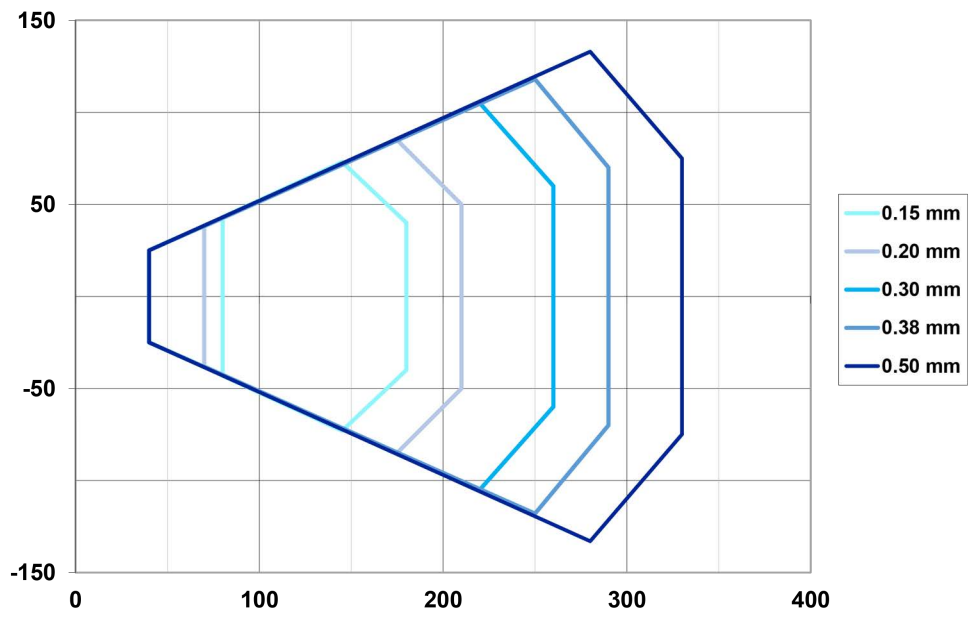

Conditions	
Hardware Settings	
Code Symbology	Code 128
Tilt Angle	0°
Pitch Angle	0°
Skew Angle	15°
Software Parameters	
Exposure Time*	70 μs
Gain*	14
HDR*	Enabled

* Default settings

Blade 200 - xx0x - focus=Mid

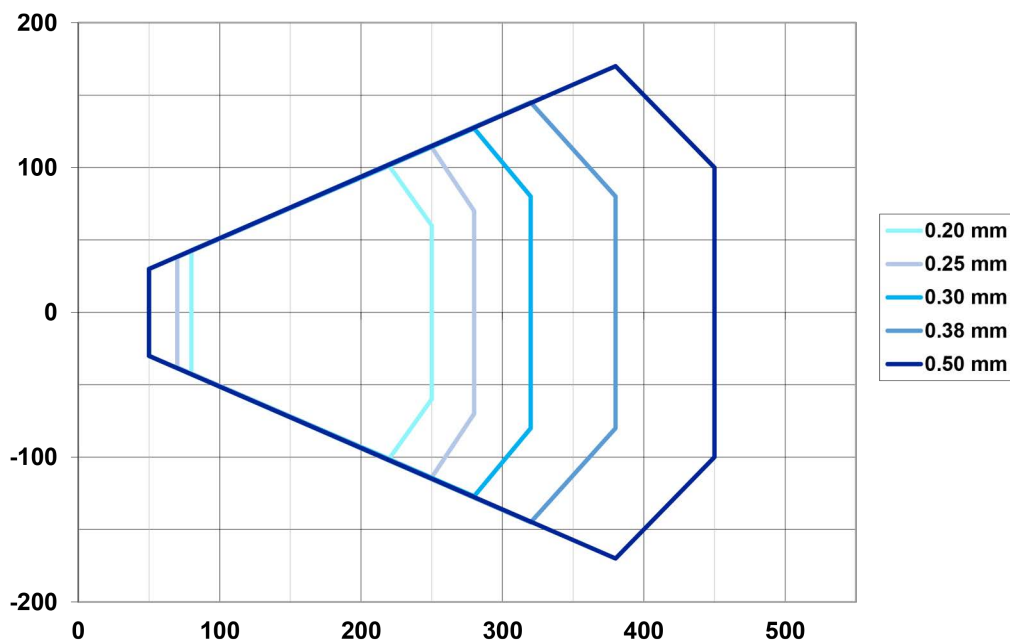

Conditions	
Hardware Settings	
Code Symbology	Code 128
Tilt Angle	0°
Pitch Angle	0°
Skew Angle	15°
Software Parameters	
Exposure Time*	85 μs
Gain*	14
HDR*	Enabled

* Default settings

Blade 200 - xx0x - focus=Far

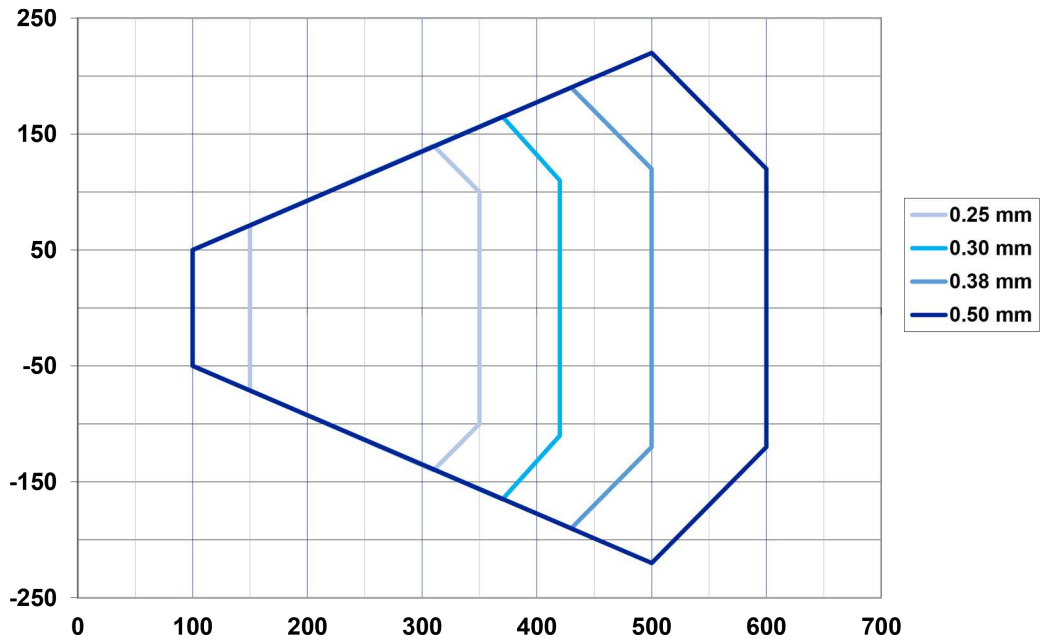

Conditions	
Hardware Settings	
Code Symbology	Code 128
Tilt Angle	0°
Pitch Angle	0°
Skew Angle	15°
Software Parameters	
Exposure Time*	100 μs
Gain*	14
HDR*	Enabled

* Default settings

CONSIDERATION ON LABEL MOVING SPEED

To determine if a moving label can be successfully read, the following consideration must be taken into account.

“Picket Fence” reading mode

In picket fence reading mode, the code motion direction is perpendicular to the bars of the code:

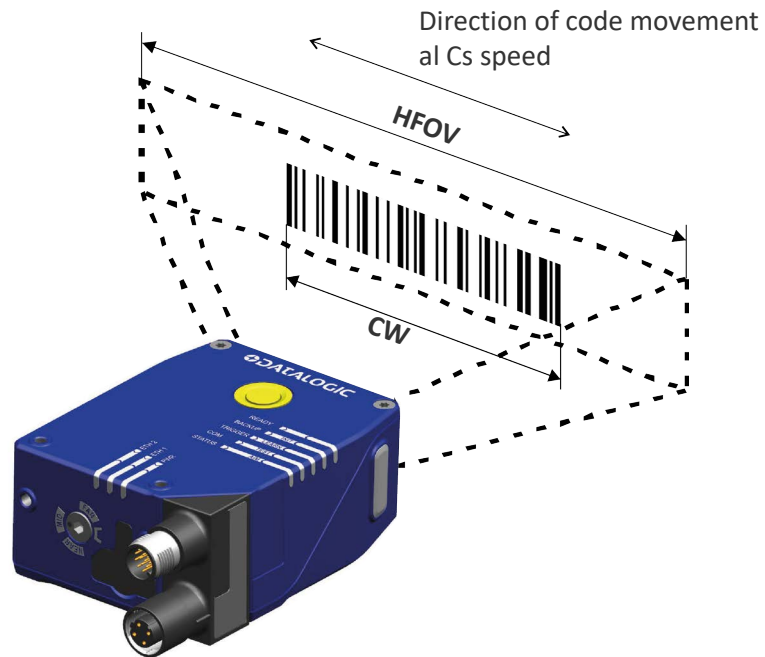

Figure 50 - “Picket Fence” reading mode

Code Width and Frame Rate

In order to have a successfully reading, at least one image containing the entire code has to be taken:

- CW= code width (mm)
- CS = Code Speed (mm/s)
- HFOV = Horizontal FOV (mm) (depends on the code distance from the reader)
- Fr = Reader Frame Rate (Image/s)

The following condition needs to be met:

$$\text{HFOV} - \text{CW} \geq (1/\text{Fr}) * \text{Cs}$$

By default Blade frame is 250 fps, that means that the image are take every 4 ms.

If for example the code is moving at 1 m/s, its position will translate by 4 mm every image. So the HFOV must be least 4 mm longer than the CW.

Blur effect and Exposure Time

The Exposure Time parameter defines the time during which the image will be exposed to the reader sensor to be acquired.

Taking images of moving object can lead to a blur effect, that depend on the image exposure time.

Assuming:

- X: Code Resolution (mm)
- Texp: Exposure Time (s)
- Cs: Code Speed (mm/s)

To prevent an excessive blur effect, this minimum condition has to be met:

$$Cs * Texp < X$$

The default Exposure Time depends on models / focus position, and are listed in the following table:

Blade 100 - 1xxx	85 μ s
Blade 100 - 2xxx	75 μ s
Blade 200 - Near Focus	70 μ s
Blade 200 - Near Focus	85 μ s
Blade 200 - Near Focus	100 μ s

“Step Ladder” reading mode

In “Step Ladder” reading mode, the code motion direction is parallel to the bars of the code:

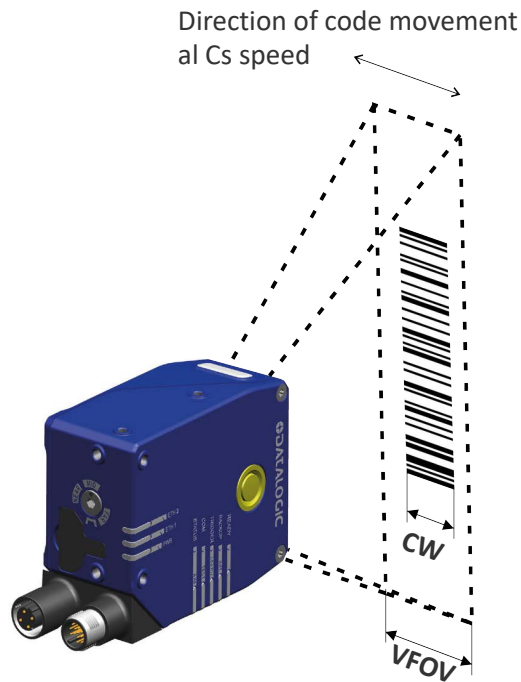

Figure 51 - “Step Ladder” reading mode

CH= code Height (mm)

CS = Code Speed (mm/s)

VFOV = Vertical Fov (mm) (depends on the code distance from the reader)

Fr = Reader Frame Rate (Image/s)

Code Width and Frame Rate

In order to have a successfully reading, at least one image containing the entire code has to be taken.

In the near field the VFOV of the reader is small, if we neglect it the condition that has to be fulfilled is simply:

$$CH \geq (1/Fr) * Cs$$

By default Blade frame is 250 fps, that means that the image are take every 4 ms.

If for example the code is moving at 1 m/s, its position will translate by 4 mm every image. So the CH must be least 4 mm.

In the far field the VFOV is more significant, and can be taken into consideration to relax the above constraint.

Blur effect and Exposure Time

The amount of the blur on the code due to the motion depends on the orientation of the bars, and so varies with the label tilt angle.

As a reference “worst case” value we can use the same condition given for “picket fence” mode, and so:

$$Cs * Texp < X$$

If there is no tilt, and the movement direction is always perpendicular to the code bars, this condition can be significantly relaxed.

CHAPTER 8

DL.CODE SOFTWARE CONFIGURATION

Software configuration of your Blade for static reading or simple code reading applications can be performed using the X-PRESS HMI (which requires no external configuration program). This procedure is described in “X-PRESS Human Machine Interface” on page 68.

For the majority of applications however you will use DL.CODE, connecting to the reader through the on-board Ethernet interface.

DL.CODE SYSTEM REQUIREMENTS



CAUTION: DL.CODE does not currently support Windows Embedded (often used in industrial PCs and/or PLCs).



NOTE: To install and run DL.CODE you should have a Laptop or PC. Refer to the DL.CODE software user manual for know the minimum system requirements.

CONFIGURATION USING DL.CODE



NOTE: Especially for lengthy configurations, it is always good practice to periodically save the configuration to permanent memory (Save on Device) to avoid losing the configuration in Temporary Memory. You must give a name to the new configuration or overwrite an existing one (except for Default which cannot be modified).



NOTE: If a valid micro SD Card is present, the backup on it is automatically updated every time a configuration is saved in permanent memory. See “Backup and Restore Through Micro SD Card” on page 118.

When all the configuration parameters are set correctly and saved to the device, you can perform a Backup to File and/or to an External storage device (BM100, etc.). See “Backup and Restore Through DL.CODE” on page 119.



NOTE: Datalogic guarantees that the reader's permanent memory can store at least 50 configurations without script formatting or with a script with less than 2048 characters. The actual number of configurations may be larger depending on the type of configuration and Blade model. In addition to your application configuration(s), the Default configuration is always present on the reader and in fact it is not modifiable and cannot be deleted.

Installing DL.CODE Configuration Program



CAUTION: DL.CODE does not currently support Windows Embedded (often used in industrial PCs and/or PLCs).

DL.CODE is a Datalogic reader configuration tool providing several important advantages:

- Intuitive Graphical User Interface for rapid configuration
- Defined configuration directly stored in the reader
- Discovery and IP address setting features to facilitate remote configuration
- Device Monitoring

To install DL.CODE

1. On the PC that will be used for configuration, (running Windows 8.1, 10 or 11), download the DL.CODE mini-DVD.zip file. Extract the files maintaining the folder structure and run the **start.hta** file to access the installation pop-up. Click on the **Install DL.CODE** link to run the installation program and follow the installation procedure.



NOTE: To perform a “silent” installation (without user input), see the DL.CODE User’s Guide.

2. When the installation is complete the DL.CODE entry is created in the *Start>Programs* bar under “Datalogic” as well as a desktop icon. Double-click the desktop icon to run it.

This configuration procedure assumes a laptop computer, running DL.CODE, is connected to a factory default reader through the Ethernet port.

Device Discovery



NOTE: To discover models via web interface, refer to Configuration using Web Discovery, starting on page 66.

The User Interface opens and displays a list of all the devices belonging to the Local Area Network. DL.CODE has a discovery feature to accomplish this task.

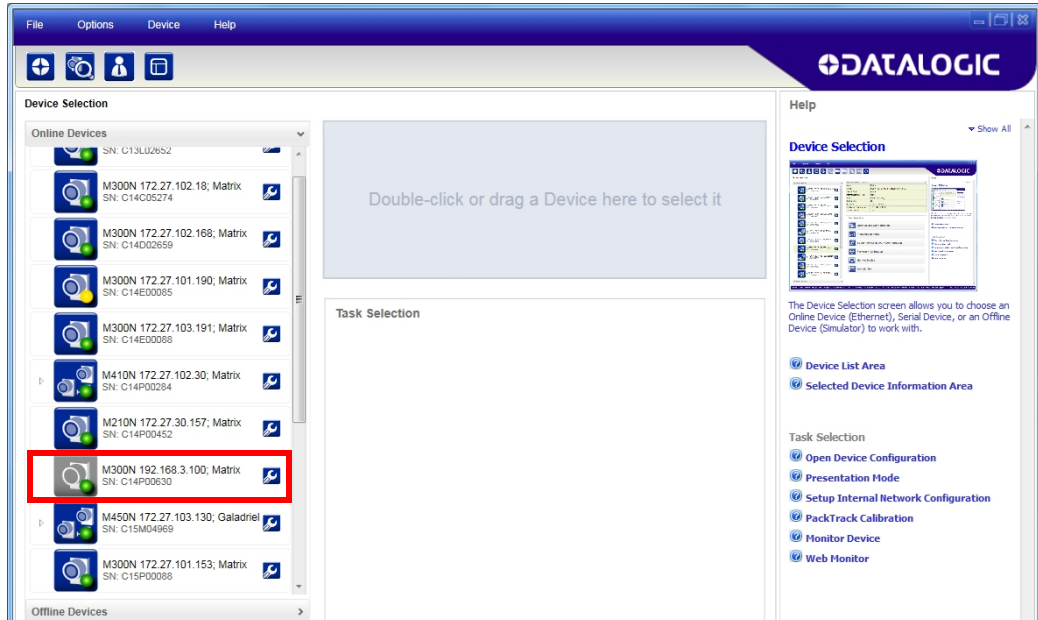

Figure 52 - Device Discovery

The discovery feature will also show devices not belonging to the LAN and display them in gray (see Figure 52).

3. First the device must be added to the LAN by aligning its IP Address to the network. The network administrator should provide valid LAN address(es).
4. Find your device in the list by matching its serial number (SN) then click on the device wrench icon to open the Device Environment Configuration window.
5. Change the Ethernet Settings (IP Address, Subnet Mask, Gateway Address etc.) according to the network requirements.

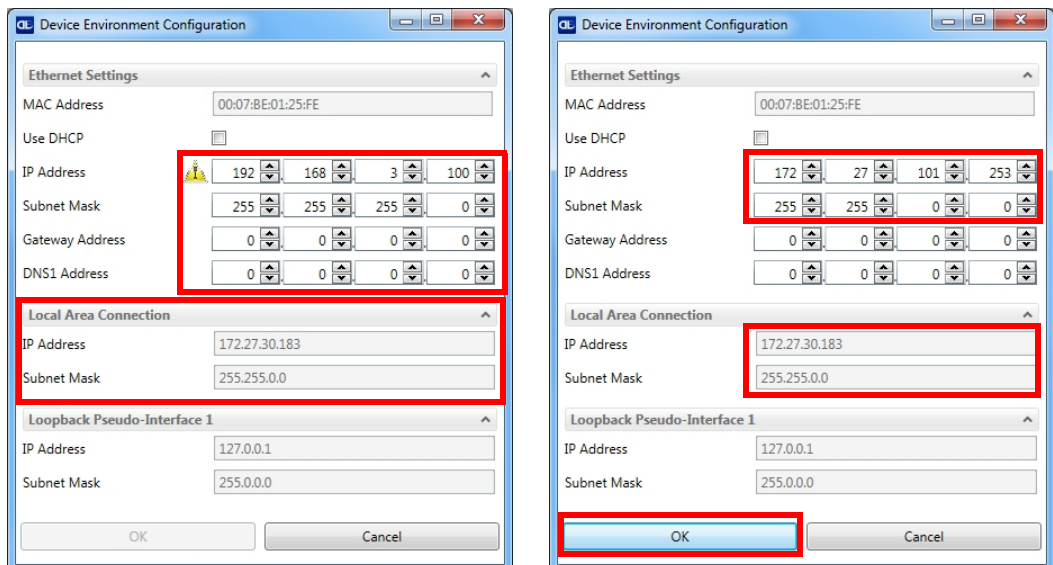
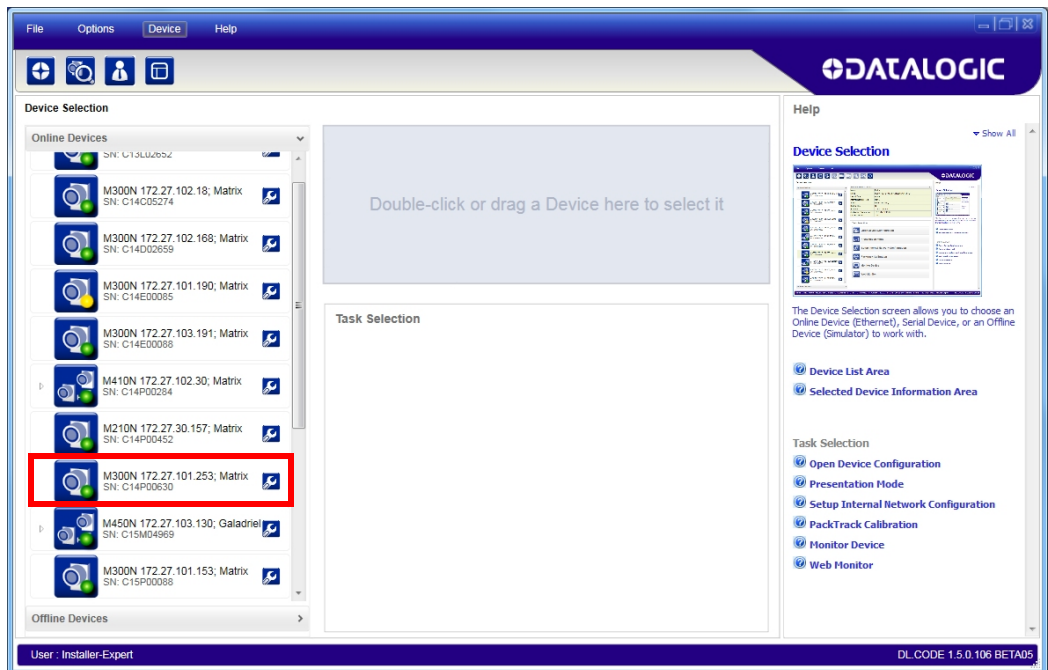

Figure 53 - Device Environment Configuration Window

- Click OK; the device will reappear in the list of Online Devices (in color) meaning it is now part of the LAN and can be configured. The new IP address will also be displayed.



- Double-click on or drag the device icon into the Selected Device Information Area. Details about the device will be displayed in this area.

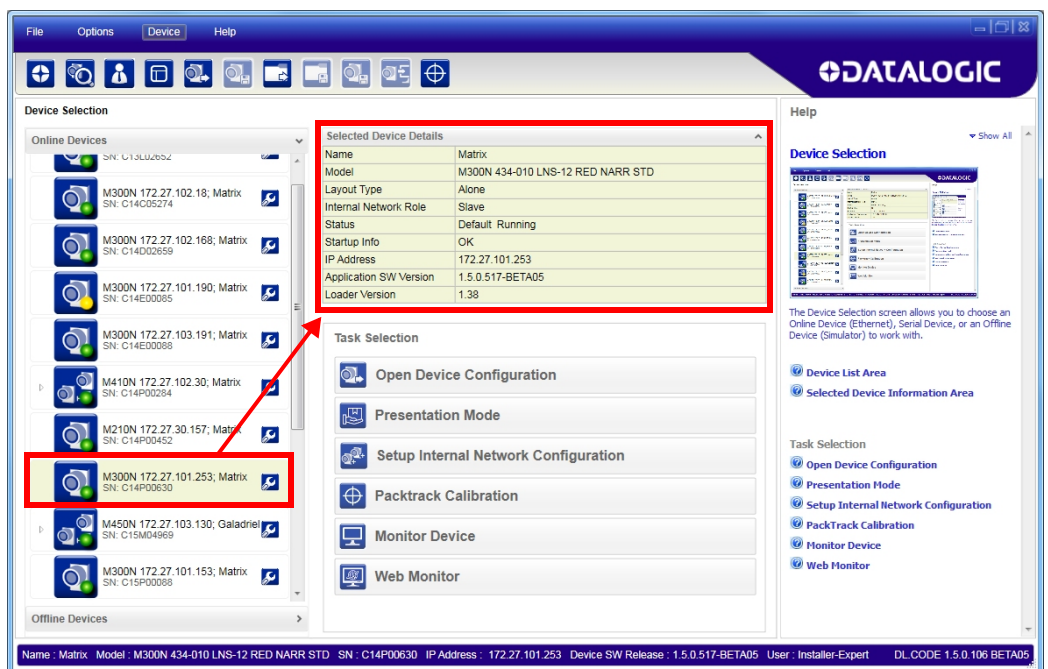
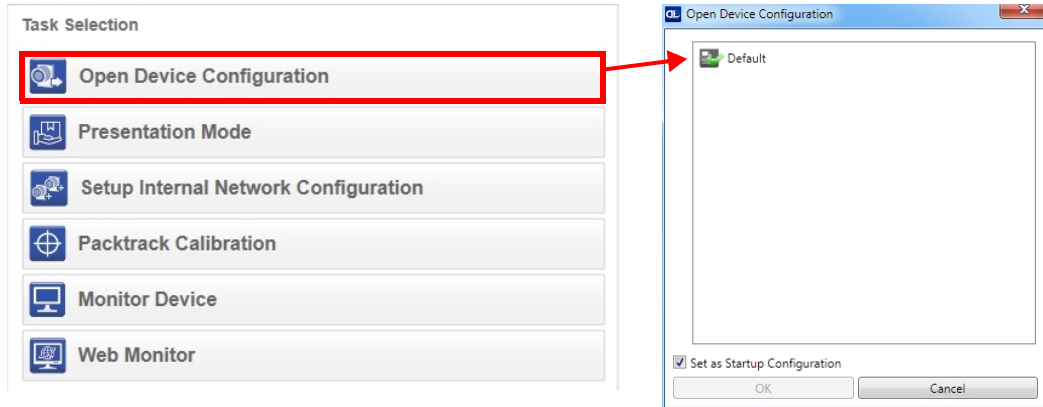

Figure 54 - DL.CODE Opening Window

For further details on advanced product configuration, refer to the DL.CODE User's Guide available in the DL.CODE Help menu.

Device Configuration



1. From the Task Area select Open Device Configuration.
2. The Open Device Configuration window opens showing the list of currently saved configurations (jobs) saved on the device. For new devices, the only saved job is the Default configuration. Click OK. The device enters run mode and begins acquiring images.

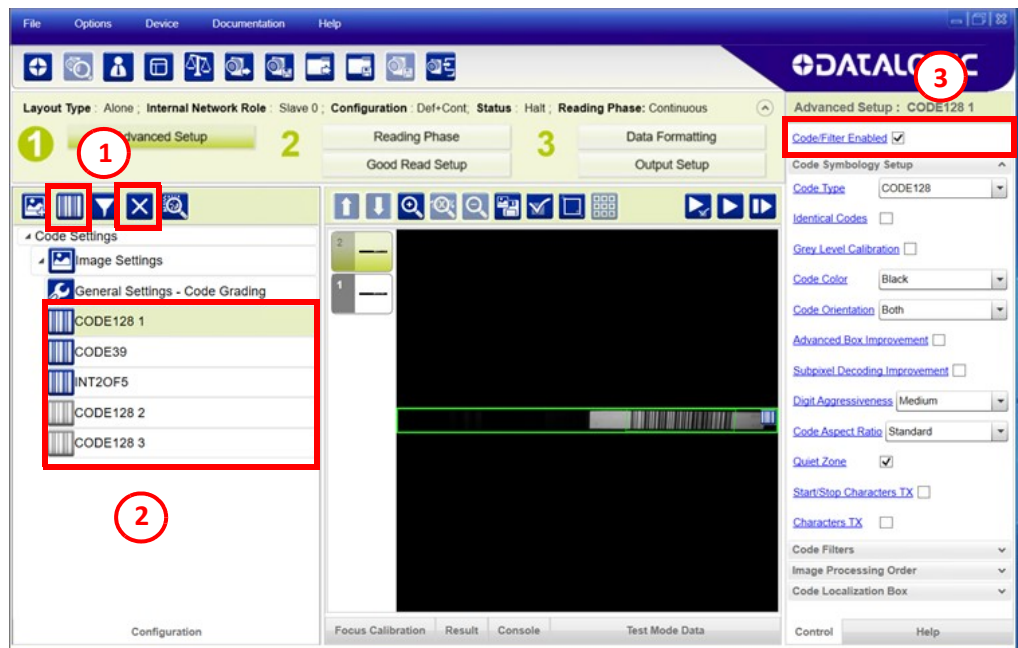

Code Settings

Initially there are five decoding tools, three of which are already enabled.



AREA	DESCRIPTION
1	<p>Add/Remove buttons:</p> <p> This button allows to add a decoding tool.</p> <p> This button allows to remove a decoding tool.</p>
2	<p>Decoding tools area:</p> <p>The decoding tools are displayed in this area.</p> <p>NOTE: Disabled slots are displayed in gray.</p>
3	<p>Enabled/Disabled check box:</p> <p>This check box allows to enable or disable the decoding tools selected in area 2.</p>



NOTE: When a slot is disabled, its properties are still kept in memory and applied when it is re-enabled.



NOTE: It is also possible to enable or disable the slots via Host Mode Programming (see "Host Mode Programming" on page 91).

Reading Phase

1. Select your application specific Operating Mode from the icons over the Configuration Parameters tree area: Continuous or Phase Mode.

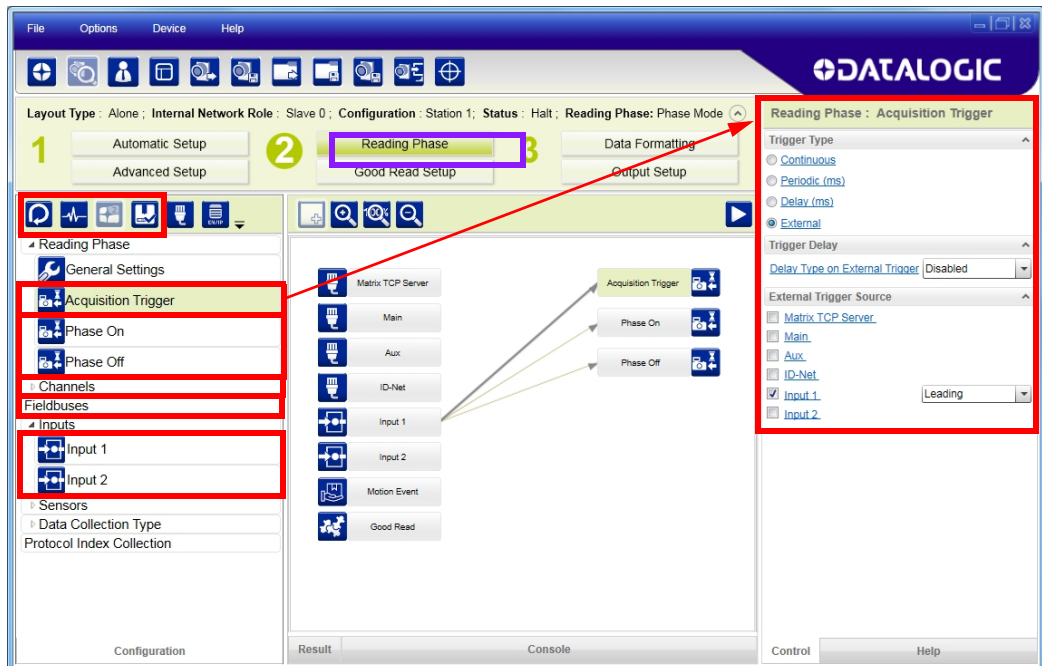

2. Configure the relative Operating Mode parameters from the Reading Phase parameters panel. Different groups will appear in the panel depending on the selected icons over the Configuration Parameters tree area.



CAUTION: If the same signal activates multiple events with the same edge, those events are fired in a random order.

If the same channel activates multiple events with the same string, those events are fired in a random order.

AVOID doing this action. The reader may not work properly, the result is not predictable!.

Good Read Setup

1. Select your specific data collection type from the icons over the Configuration Parameters tree area: Code Collection, Code Combination, Presentation or Match Code. Not all data collection types are available for all Operating Modes; for example PackTrack Operating Mode only supports Code Combination. Incompatible data collection types will be shown in grey and cannot be selected. The following example shows Code Combination. By default, the Expected Codes (when more than one code type is selected), are in logical AND, which means that all codes are required to be decoded to produce a Good Read condition.

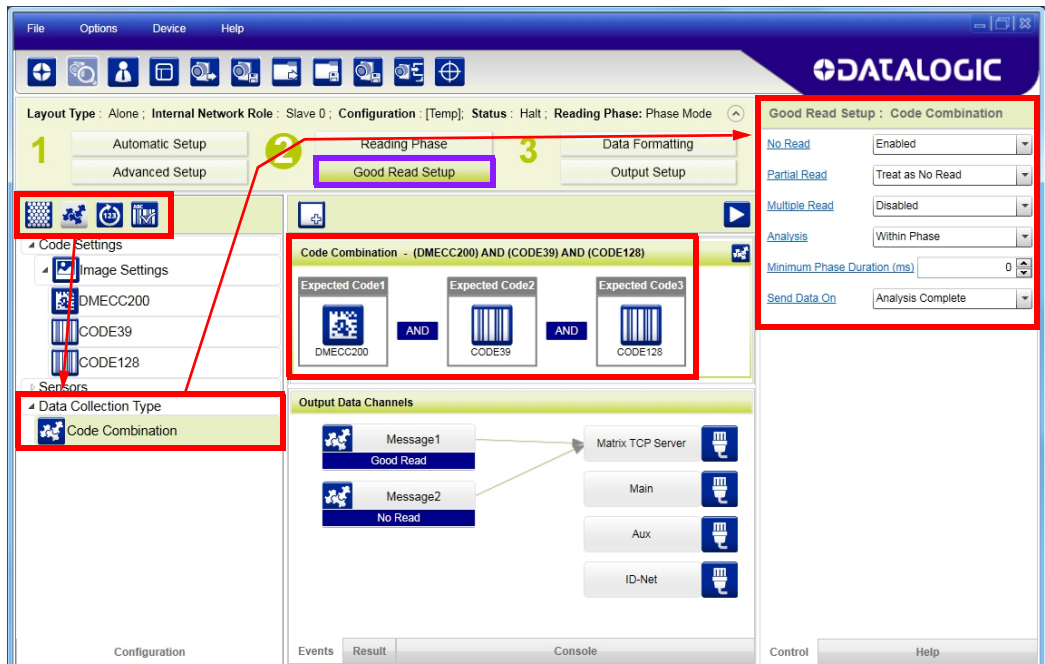

2. If a Good Read condition should be produced when any single code is decoded, independent from the others, then they need to be combined in logical XOR. To do this, drag the code icon(s) from their relative Expected Code box into the Expected Code box of the XOR combination you wish to create. Then delete the empty box by selecting it with the mouse (highlighted) and pressing the delete key on your keyboard.

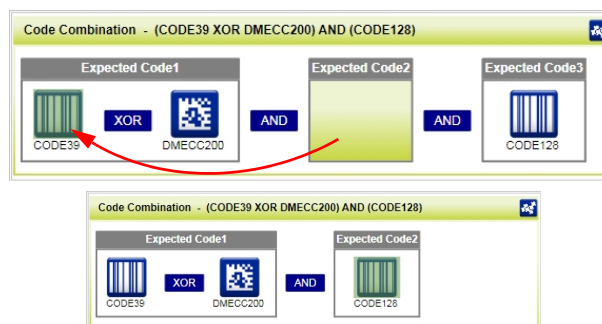

To create a logical AND condition from a logical XOR, create a new Expected Code box using the Add icon. Then drag the desired code icon from one box to the other.

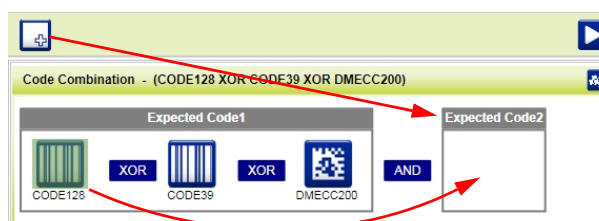

Data Formatting

1. Configure your application specific Data Formatting Message(s) from the Configuration Parameters tree area: Message 1, Message 2, etc.

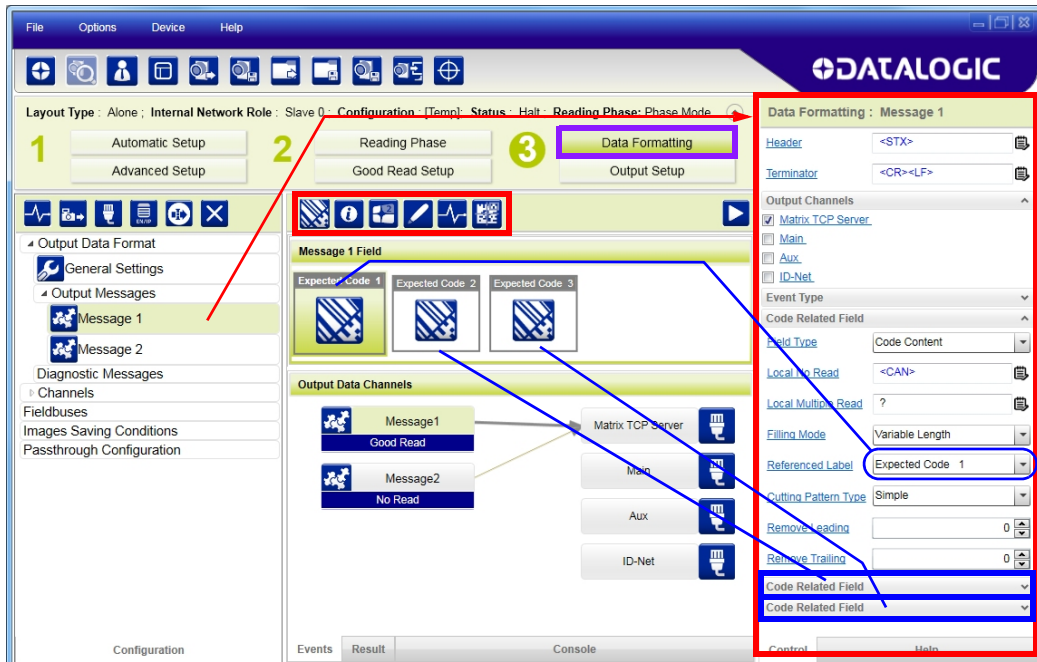

You can add fields to the output message by clicking on the icons above the Message Field area. They will be appended to the message. You can drag them to position them between other fields in the message so that the output message is ordered according to your application requirements.

Each field has its own relative configuration parameters in the parameters panel.

Output Setup

1. Configure your application specific Digital Output(s) from the Configuration Parameters tree area: Output 1, Output 2, etc.

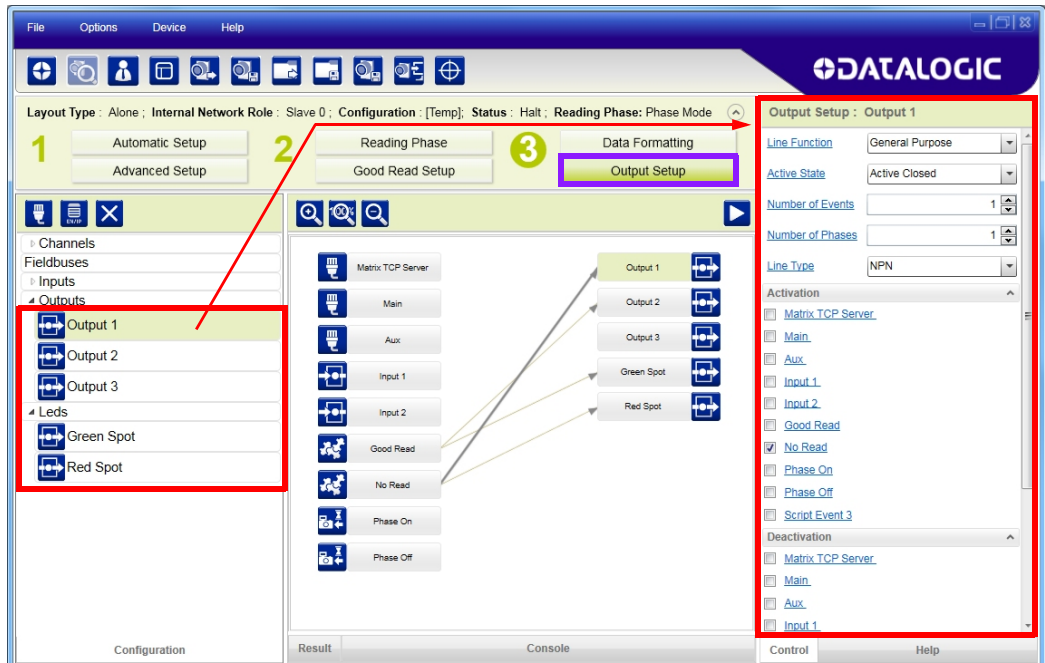

NOTE: Remember to save the configuration to permanent memory (overwriting the previous configuration, or creating a new one).



NOTE: When a configuration is saved in permanent memory, if a micro SD card is inserted in the reader the backup on it will be automatically updated.

Host Mode Programming

The reader can also be partially configured from a host computer using the Host Mode programming procedure.

Manual Calibration

The following examples show some of the typical conditions occurring during the installation and how they can be tuned manually:

Under-exposure

To correct this result it is recommended to change the following parameters in their order of appearance:

1. increase the **Exposure Time**
2. increase the **Gain**



NOTE: In general, a longer exposure time corresponds to a lighter image but is susceptible to blurring due to code movement. Exposure time is also limited by the Internal Lighting mode parameter. Longer exposure times can be set if the power strobe level is lowered. High gain settings may produce a grainy image that may affect the decoding process.

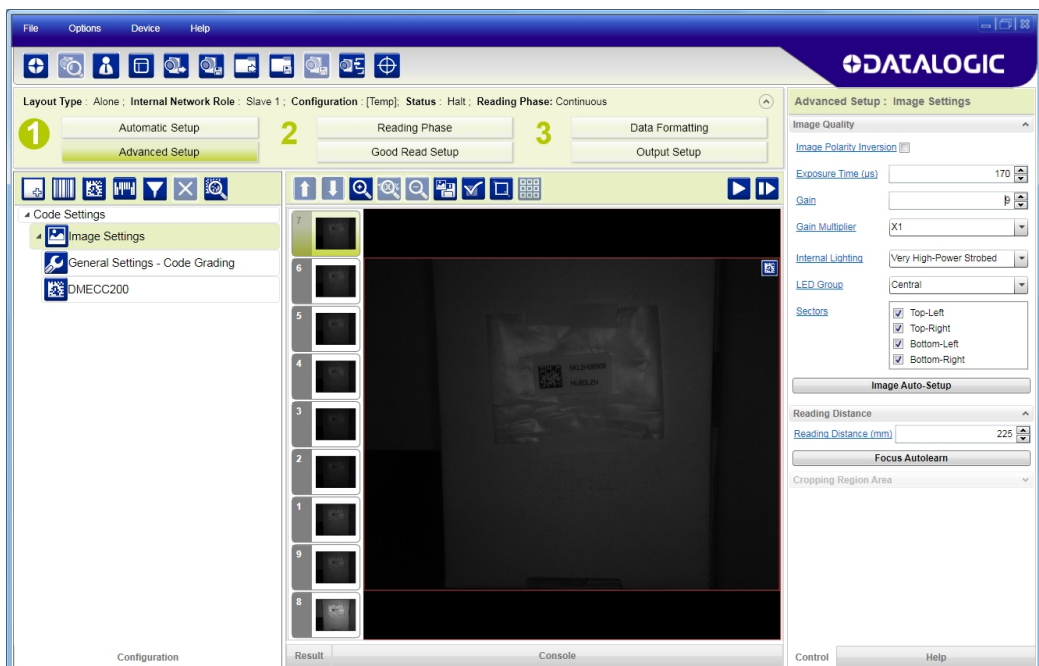

Figure 55 - Example Under Exposure: Too Dark

Over-exposure

To correct this result it is recommended to change the following parameters in their order of appearance:

1. decrease the **Gain**
2. decrease the **Exposure Time**

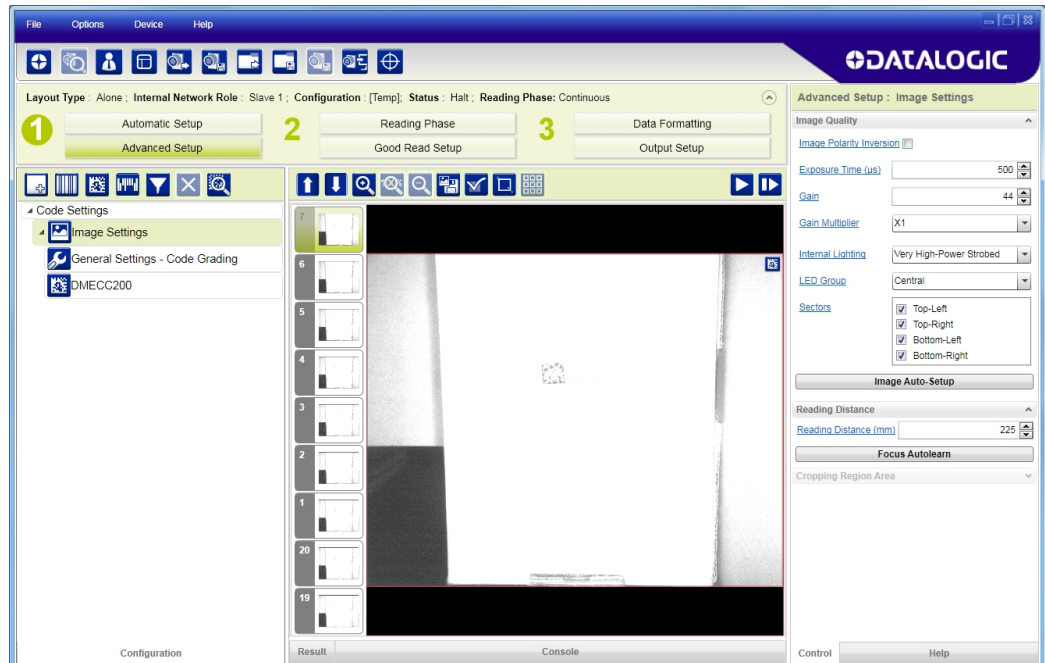

Figure 56 - Example Over Exposure: Too Light

Moving code out of the Field of View

To correct this result and have the code completely visible in FOV, it is possible to follow one or both the procedures listed below:

- reposition the reader
- use the **Delay on Trigger** and set the **Time** or **Space** values.

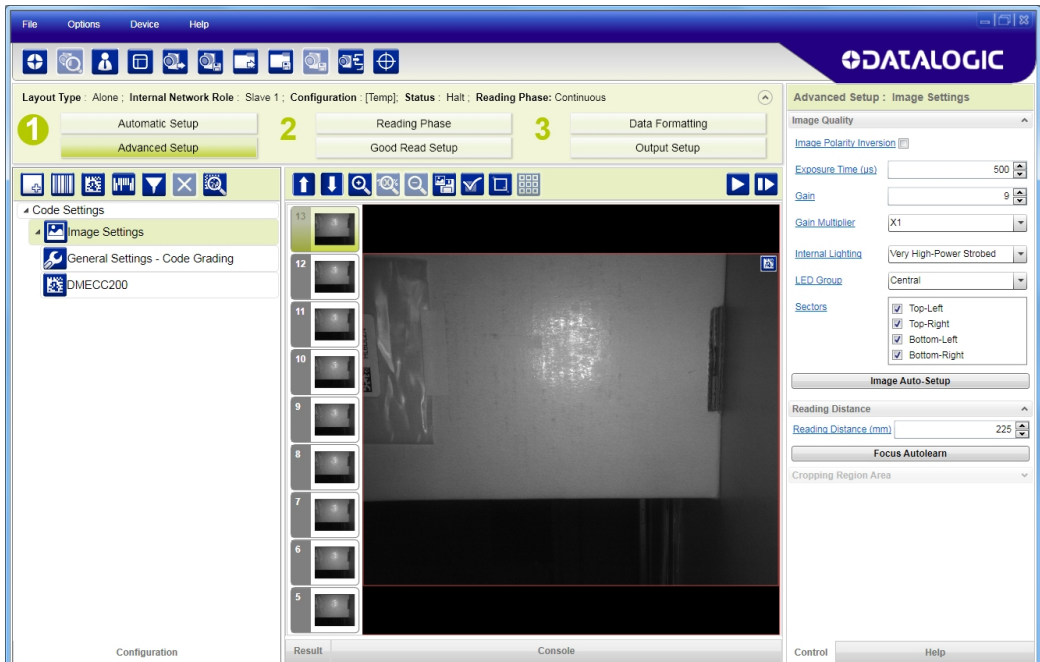

Figure 57 - Example Out of FOV

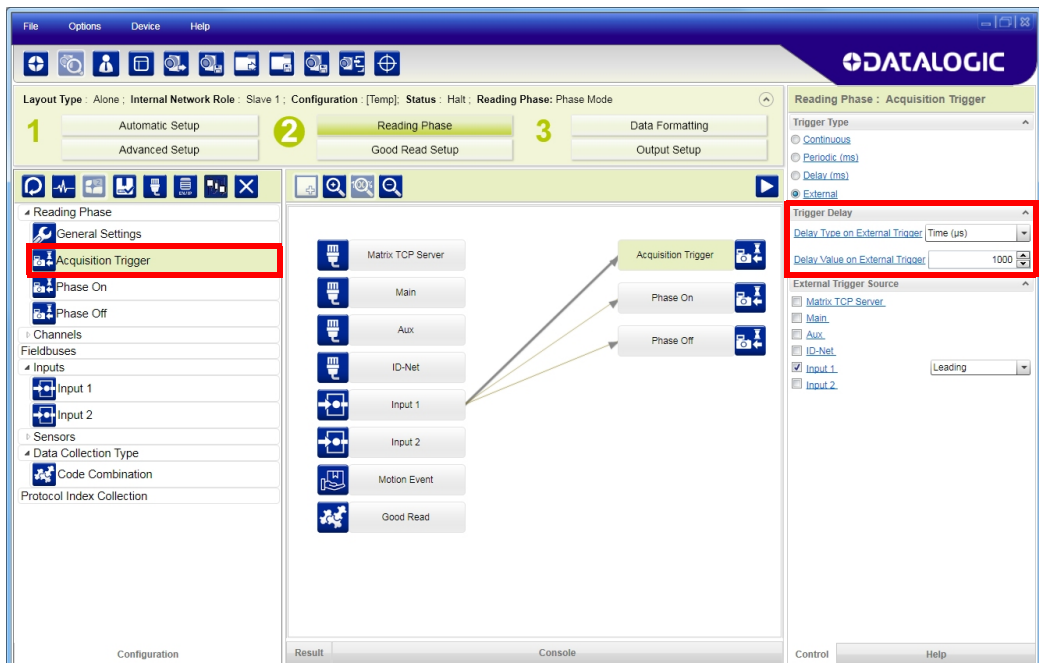

Figure 58 - Add Delay on Trigger to Correct Out of FOV

PASS-THROUGH CONFIGURATIONS

DL.CODE and Blade readers support pass-through multi device configurations.

The pass-through configuration allows individually working devices (Alone), to collect data from other devices (also working Alone), and pass this data to a third device through a different communication channel.

The following screenshots show the pass-through configuration settings for the three devices in the example in "Pass-Through" on page 57.

Layout Type : Alone Internal Network Role : Slave 0 ; Configuration : Station 1; Status : Halt ; Reading Phase: Phase 3

Reader #1

Reading Phase 3 Data Formatting

Good Read Setup Output Setup

Output Data Format

Output Messages

Message 1

Message 2

Diagnostic Messages

Channels

Matrix TCP Server 1

Matrix TCP Server 2

Main

Aux

Fieldbuses

Images Saving Conditions

Passthrough Configuration

Passthrough

Passthrough Field

Output Data Channels

Good Read

Message1

No Read

Message2

Matrix TCP Server 2 Passthrough

Matrix TCP Server 1

Matrix TCP Server 2

Main

Aux

Data Formatting : Passthrough

Header: <STX>

Terminator: <CR><LF>

Passthrough Input Data

Header: <STX>

Terminator: <CR><LF>

Inout Channel: Matrix TCP Server 2

Passthrough Content Field

Output Channels

Matrix TCP Server 1

Matrix TCP Server 2

Main

Aux

Layout Type : Alone Internal Network Role : Slave 0 ; Configuration : Station 2; Status : Halt ; Reading Phase: Phase 3

Reader #2

Reading Phase 3 Data Formatting

Good Read Setup Output Setup

Output Data Format

Output Messages

Message 1

Message 2

Diagnostic Messages

Channels

Matrix TCP Server 1

Matrix TCP Server 2

Main

Aux

Fieldbuses

Images Saving Conditions

Passthrough Configuration

Passthrough 1

Passthrough 2

Passthrough 2 Field

Output Data Channels

Good Read

Message1

No Read

Message2

Main Passthrough1

Aux Passthrough2

Matrix TCP Server 1

Matrix TCP Server 2

Main

Aux

Data Formatting : Passthrough 2

Header: <STX>

Terminator: <CR><LF>

Passthrough Input Data

Header: <STX>

Terminator: <CR><LF>

Inout Channel: Aux

Passthrough Content Field

Output Channels

Matrix TCP Server 1

Matrix TCP Server 2

Main

Aux

The screenshot displays the DL.CODE software configuration interface for a device labeled "Reader #3". At the top, the status bar shows "Layout Type : Alone", "Internal Network Role : Slave 0", "Configuration : Station 3", "Status : Halt", and "Reading Phase: Conti". A red box highlights the "Reader #3" label. Below this, there are buttons for "Reading Phase", "Data Formatting", "Good Read Setup", and "Output Setup". A large green circle with the number "3" is positioned between "Reading Phase" and "Data Formatting".

The interface is divided into several sections:

- Left Panel:** A tree view containing "Output Data Format", "Output Messages" (with sub-items "Message 1" and "Message 2"), "Diagnostic Messages", "Channels", "Fieldbuses", "Images Saving Conditions", and "Passthrough Configuration".
- Message 1 Field:** A section titled "Message 1 Field" containing a sub-section "Expected Code 1" with a blue icon.
- Output Data Channels:** A diagram showing two input channels on the left: "Good Read" (containing "Message 1") and "No Read" (containing "Message 2"). Arrows from these channels point to a list of output channels on the right: "Matrix TCP Server 1", "Matrix TCP Server 2", "Main", and "Aux".
- Right Panel:** A configuration area for "Data Formatting : Message 1". It includes fields for "Header" (set to "<STX>") and "Terminator" (set to "<CR><LF>"). Below these are sections for "Code Related Field", "Output Channels" (with checkboxes for "Matrix TCP Server 1", "Matrix TCP Server 2", "Main", and "Aux"), and "Event Type".

INTERNAL NETWORK CONFIGURATIONS

Internal Network configurations (also called Master/Slave configurations), are designed to collect data from several devices connected together in an ID-NET™ network and send data output to the Host system.

DL.CODE has a Net Autoset feature for the Internal ID-NET Network which automatically recognizes and assigns addresses to all connected Slave readers.

In order to automatically recognize the ID-NET Slaves, all devices must be physically installed and electrically connected (including ID-NET network wiring).

The general procedure (also detailed in the following paragraphs) is to:

1. Mount all the readers mechanically (refer to "[Mechanical Dimensions](#)" on page 24 and "[Mounting And Positioning Blade](#)" on page 27) and electrically (refer to "[ID-NET](#)" on page 58) with factory default settings (Layout Type = Alone, Internal Network Role = Slave).
2. Run DL.CODE and verify that all the devices are discovered and shown in the device list area.
3. Connect to the designated Master device in DL.CODE and open the **Setup Internal Network Configuration**. You will be prompted to change the device to Master. Click OK. The Slave units will automatically be recognized. See "[Master Configuration](#)" on page 97.
4. Depending on the application, select Set Default Multidata Configuration or Set Default Synchronized Phase Mode Configuration.
5. Connect to each Slave reader via Ethernet and set the Slave specific parameters depending on the application type. Save each Slave specific configuration. See "[Multidata ID-NET Network Configurations](#)" on page 99 or "[Synchronized ID-NET Network Configurations](#)" on page 103.
6. For Synchronized networks Verify/Test network performance. See "[Verify Master/Slave Synchronized Configuration](#)" on page 106.
7. Perform the **Backup current Internal Network configurations** procedure. See "[Backup and Restore](#)" on page 118.

Master Configuration

First start with the desired device to assign as ID-NET Master (current default setting is Slave). Click on Setup Internal Network Configuration from the Task area.

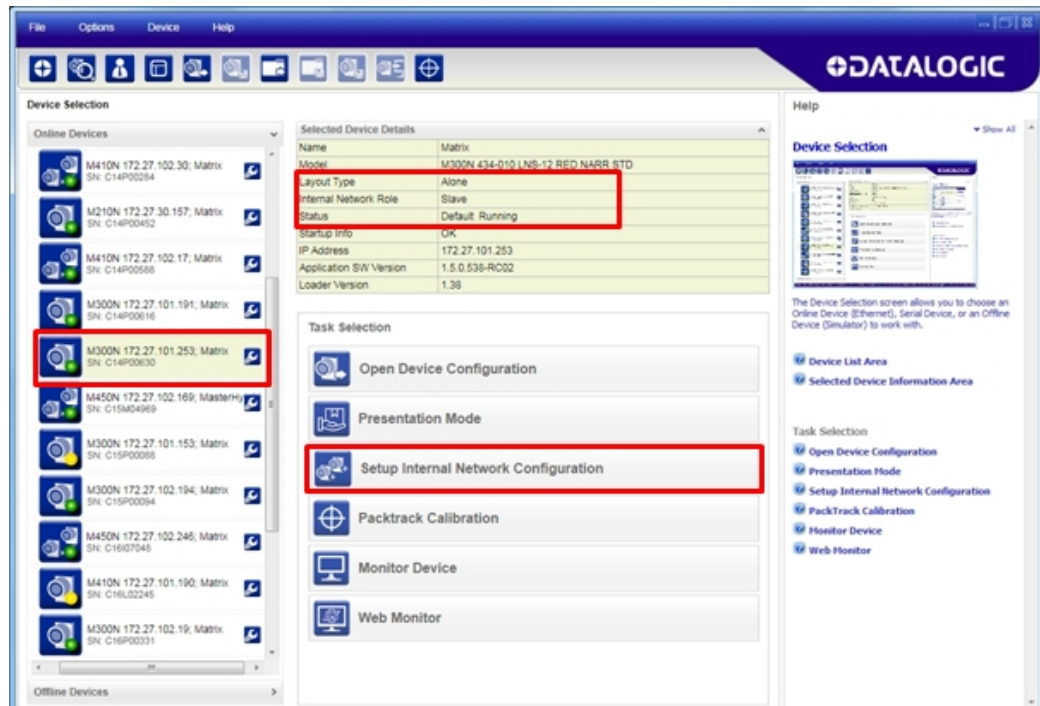

You will be advised that the device role will be changed to Master.

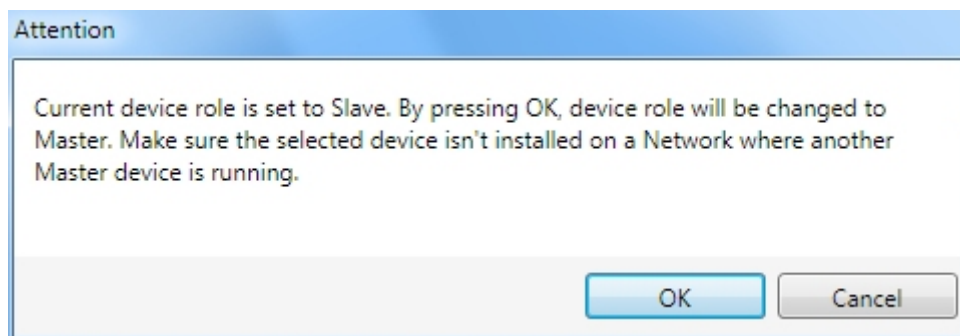

Click OK. The Net Autoset feature automatically starts to find Slave devices connected to the ID-NET network of the Master.

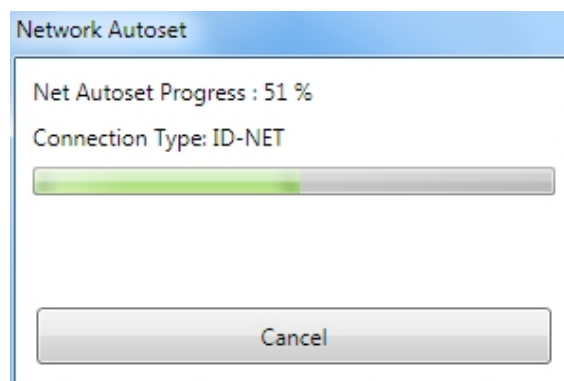

When finished, all the Slaves should have been correctly recognized. If not, verify all device connections and power and then repeat the operation by clicking on the Start Net Autoselect button.

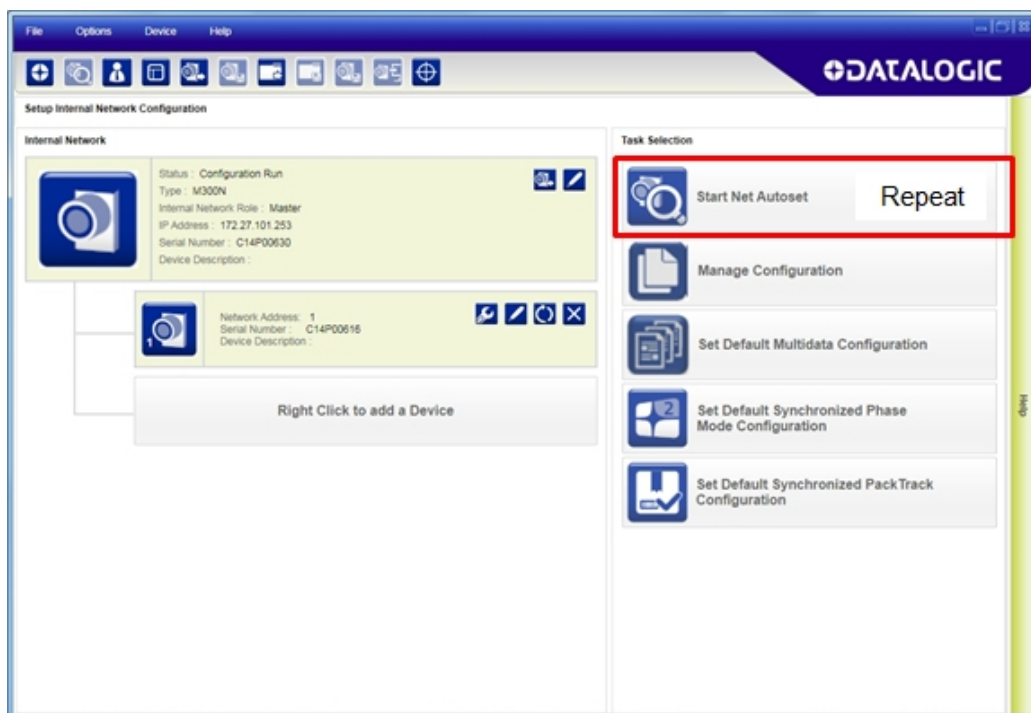

Depending on the application, select one of the Default Internal Network Configurations: **Multidata**, **Synchronized Phase Mode** or **Synchronized PackTrack**.

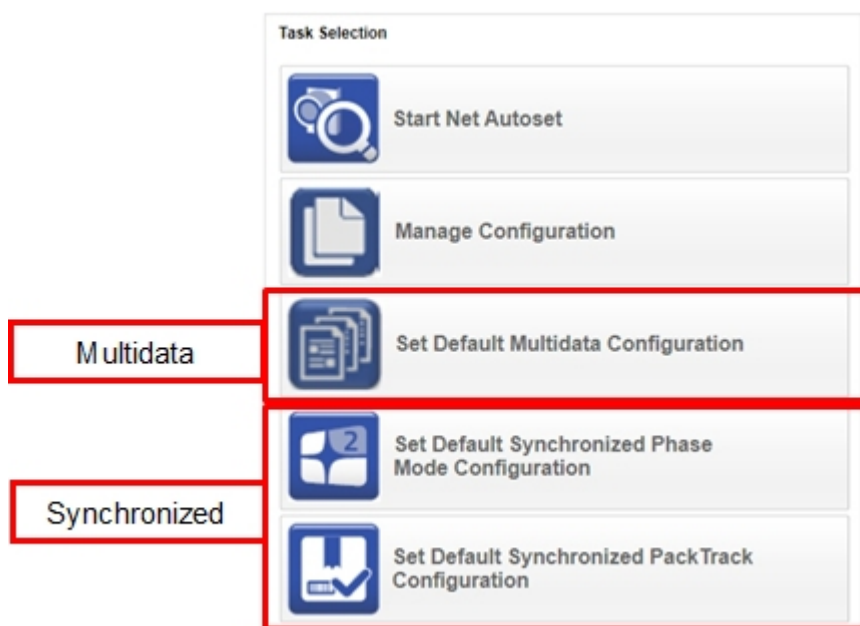

This selection will open a pre-configured job for the Master reader according to the selection. Follow the specific application instructions in the following paragraphs.

Multidata ID-NET Network Configurations

The Multidata ID-NET network communications between Master and Slave are managed by the application job (configuration) using the pass-through feature. A pre-configured job is loaded with the correct pass-through settings for both the Master and Slaves when the Default Multidata Configuration is selected from the Internal Network Setting feature.

1. Complete the configuration of all the application parameters (including Image Settings) and save them to the Master with an application specific name.

Optionally, checking the **Save on Slave Device** box can be helpful to save all the current individual Slave configurations with the new configuration *name*. This does not clone any parameters. If not checked, Slave configurations will remain as *Temp* configurations and you will be warned that changes to the Master have not been saved to the Cluster.

For Multidata configurations, the option to **Clone Master configuration on Slaves** **must not be checked**.

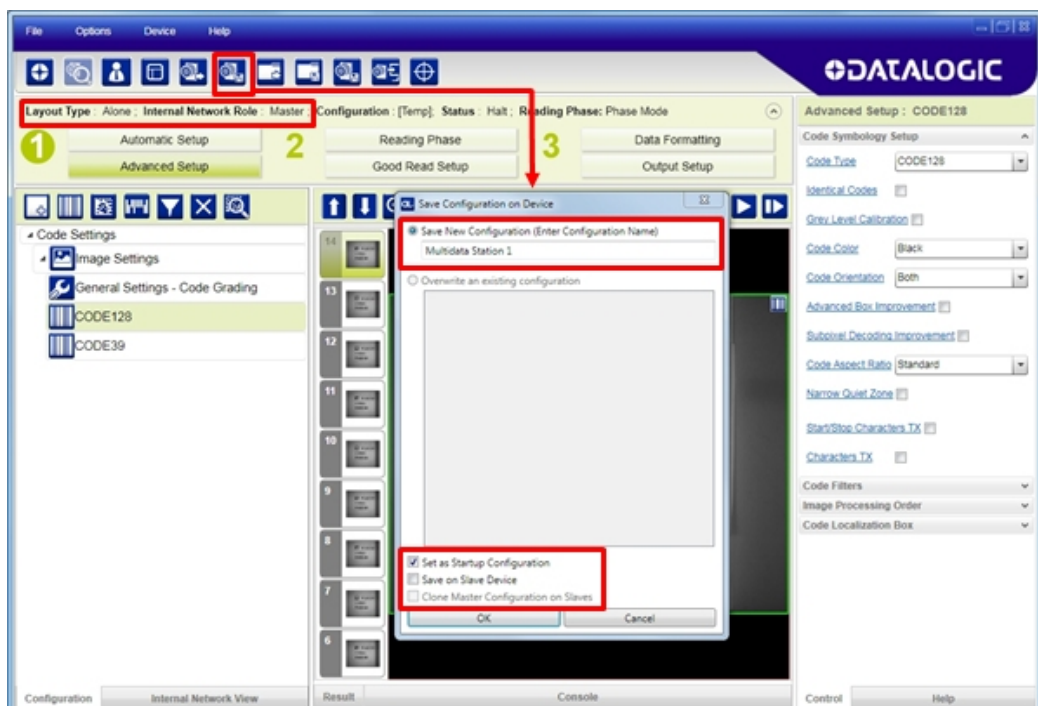

Figure 59 - Saving Multidata Configuration to Master

The jobs must not be cloned because the Master and Slaves have different input/output communication channels. The readers are also working independently from each other, often on separate stations with different code reading requirements, different operating modes, etc.

2. Connect to each Slave reader via Ethernet (see note below), and set all the configuration parameters of each Slave device.



NOTE: If necessary, Slave device photometric (Image Settings) parameters must be configured separately through DL.CODE. This is preferably done through each device's Ethernet TCP/IP channel. If Slave devices are not connected to Ethernet you must temporarily (manually) connect them one by one to perform Image Settings.

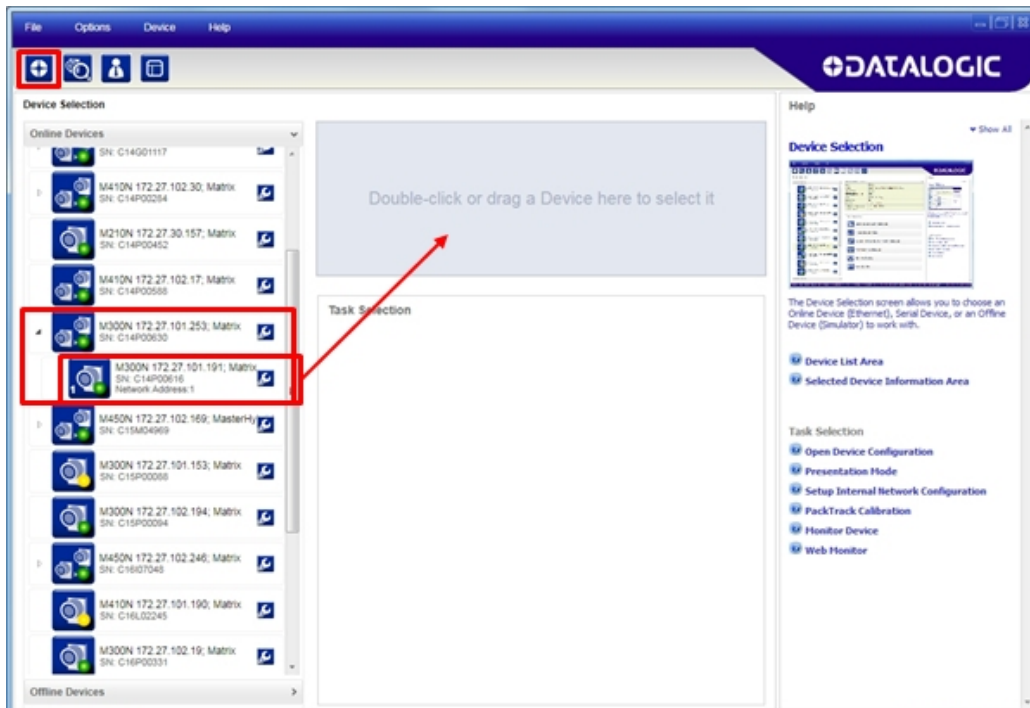

Open the **Slave specific application** job, (it will either have the new name saved from the Master or Temp depending on the **Save on Slave Device** selection).

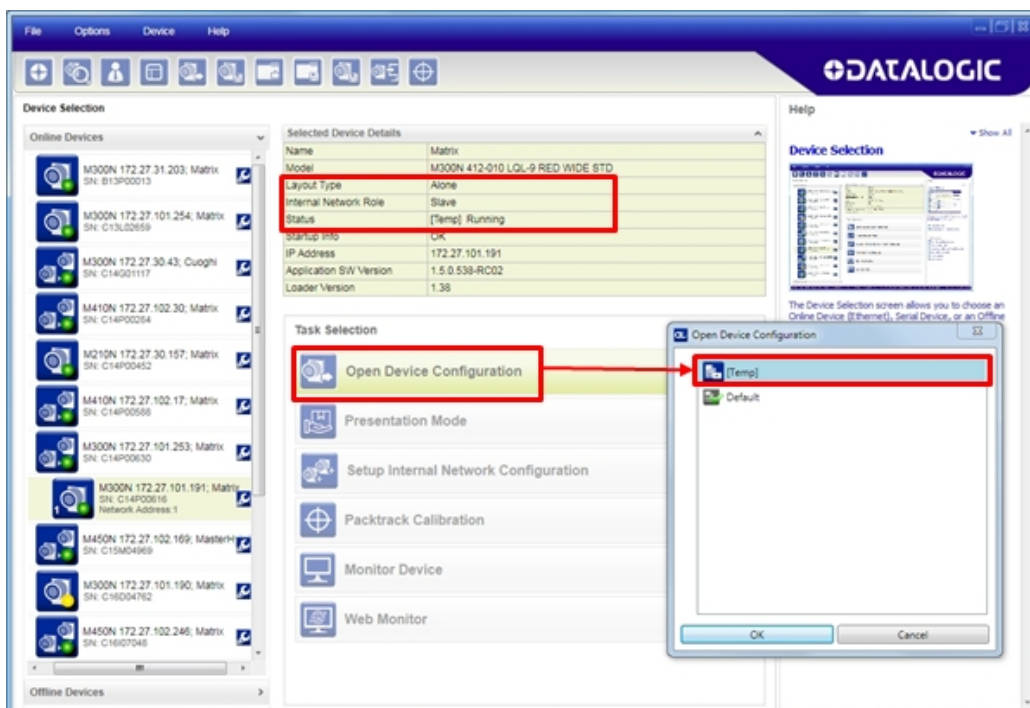

When the configuration opens, pause run mode and set all the application specific configuration parameters (including Image Settings).

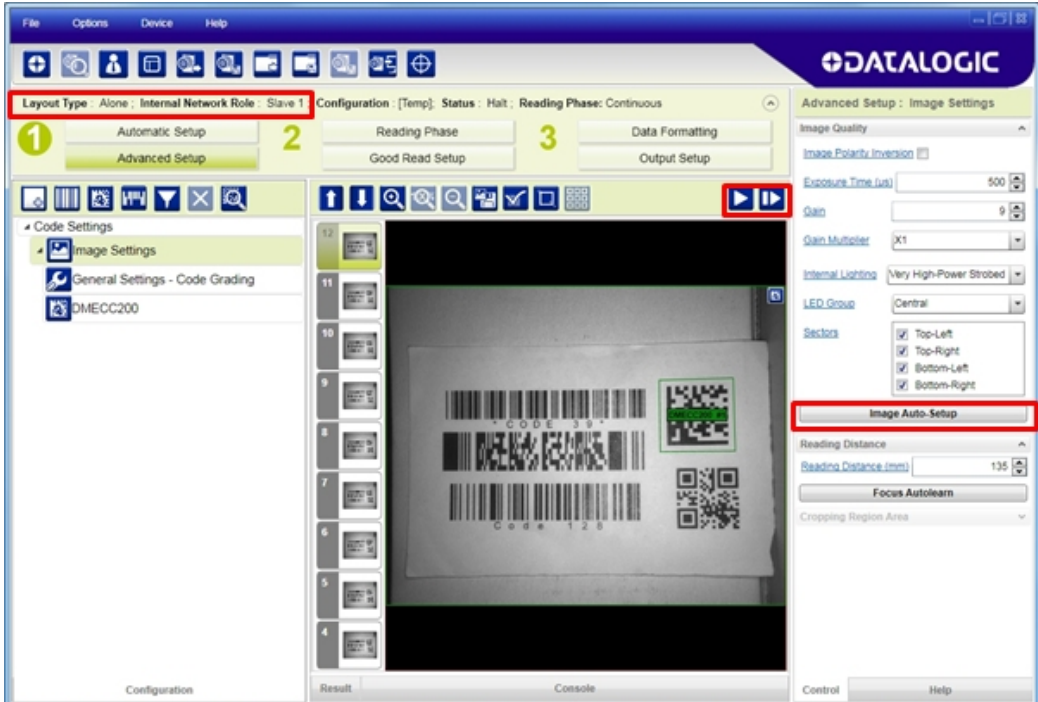

Verify the focus and decoding with the capture image button.

3. Now save them to a new Slave specific application job¹.

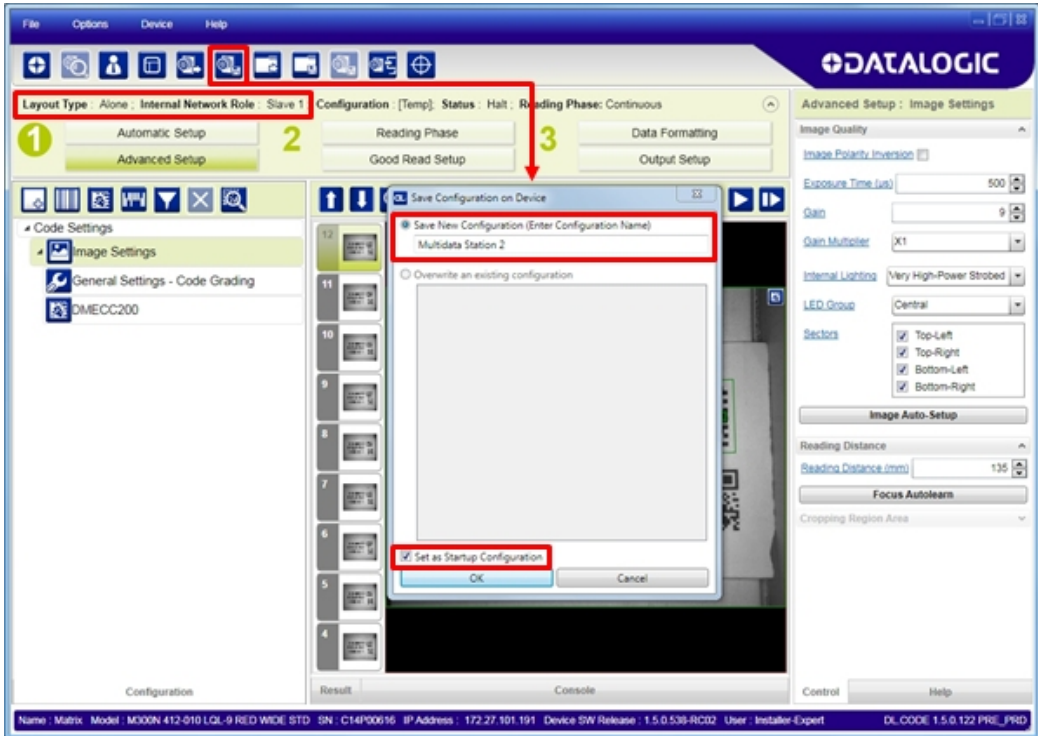
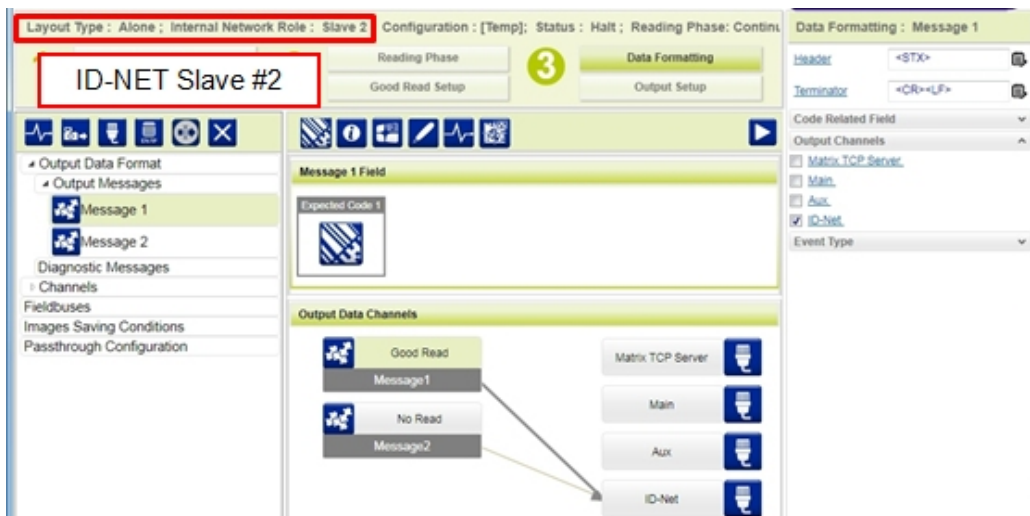
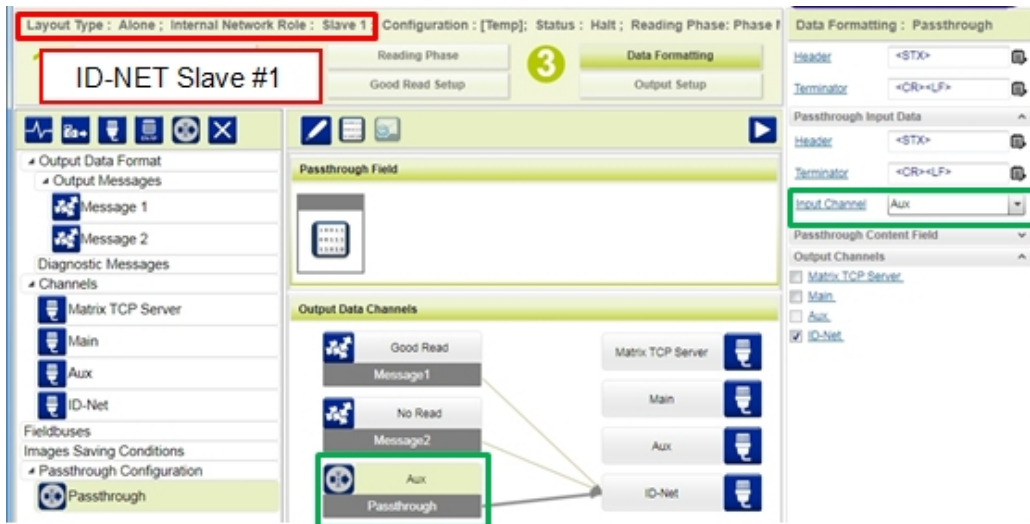
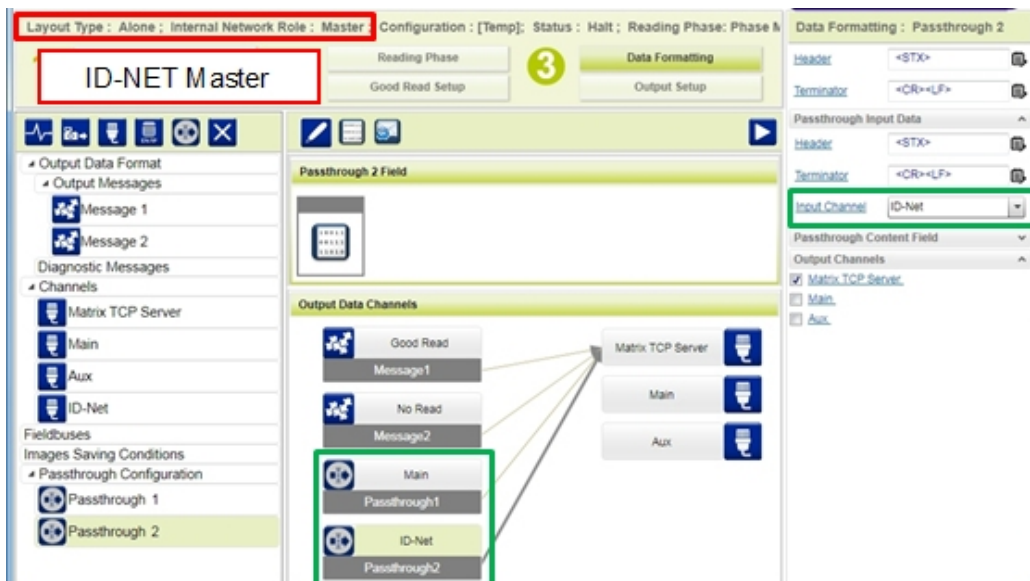

Figure 60 - Saving Multidata Configuration to Slave 1

1. If **Save on Slave Device** was selected when saving the Master configuration, an application job with the same name (but with all Slave specific configuration parameters), has been saved to the Slaves. No parameters have been cloned from the Master. There are no common parameters managed by the Master for Multidata configurations.

Repeat this procedure for each Slave device until the entire network is configured. The following screenshots show the pass-through configuration settings.



Synchronized ID-NET Network Configurations

The Synchronized ID-NET network communications between Master and Slave are internally managed by the application software. A pre-configured job is loaded with the Synchronized Layout Type and the correct Operating Mode for both the Master and Slaves when either the Phase Mode or PackTrack Configuration is selected from the Internal Network Setting feature.

1. Complete the configuration of all the application parameters (including Image Settings) and save them to the Master with an application relative name and **with the option to Clone Master configuration on Slaves**.

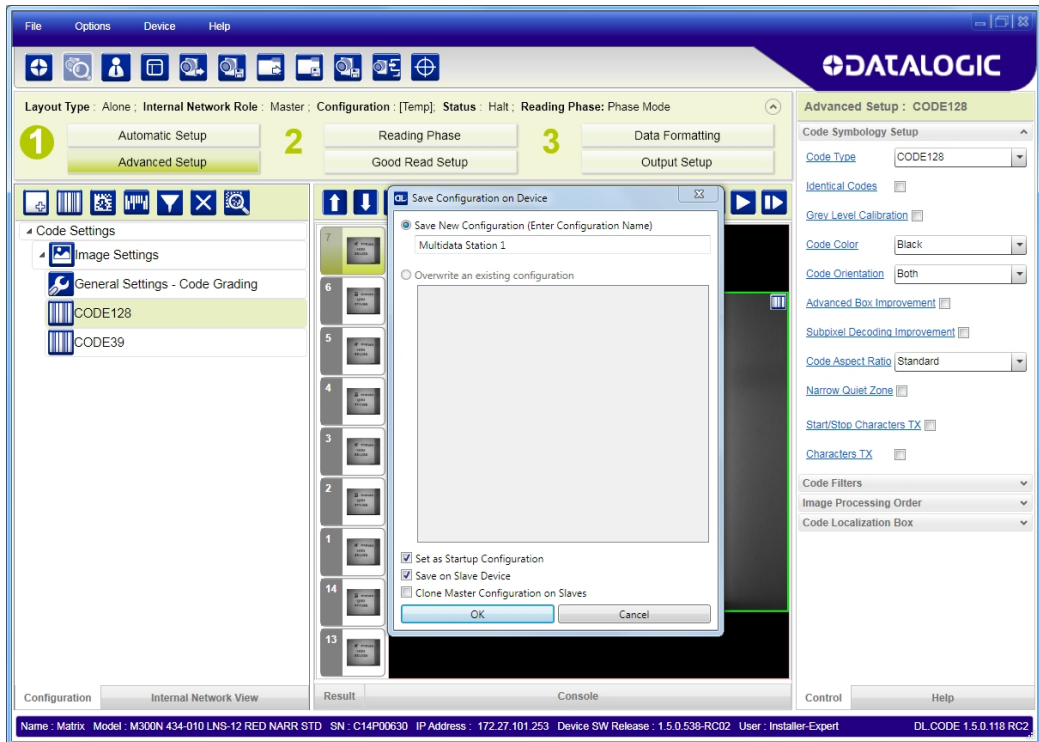
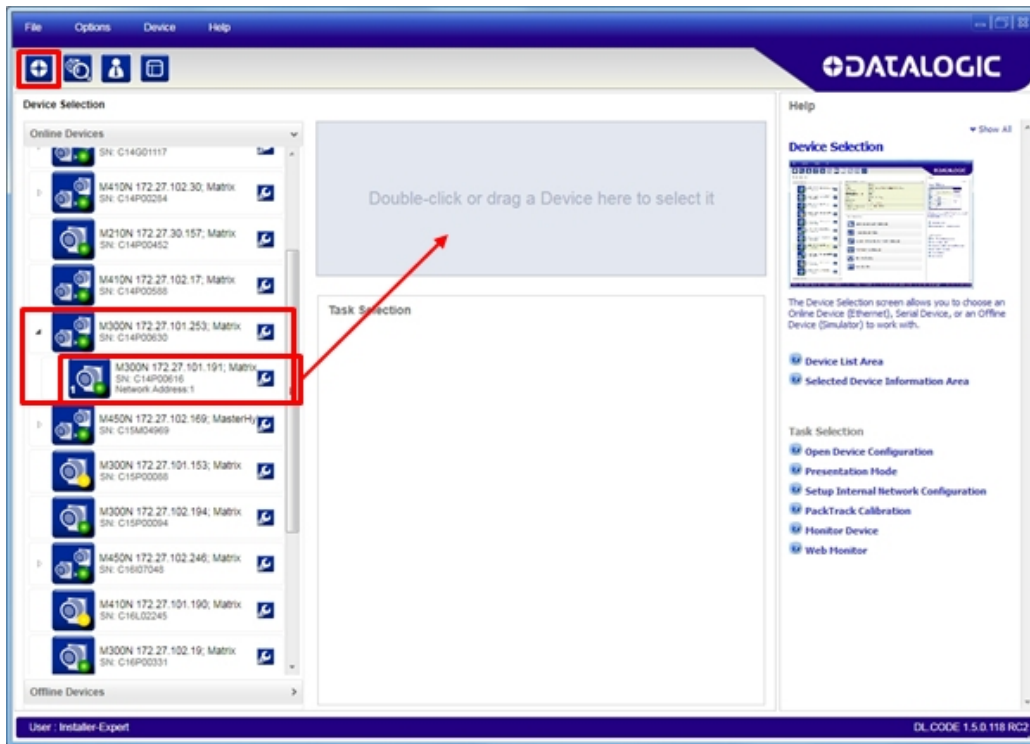

Figure 61 – Saving Synchronized Phase Mode Configuration to Master

2. Connect to each Slave reader via Ethernet (see note below), and set the Slave specific parameters.



NOTE: If necessary, Slave device photometric (Image Settings) parameters must be configured separately through DL.CODE. This is preferably done through each device's Ethernet TCP/IP channel. If Slave devices are not connected to Ethernet you must temporarily (manually) connect them one by one to perform Image Settings.



Open the cloned application job.

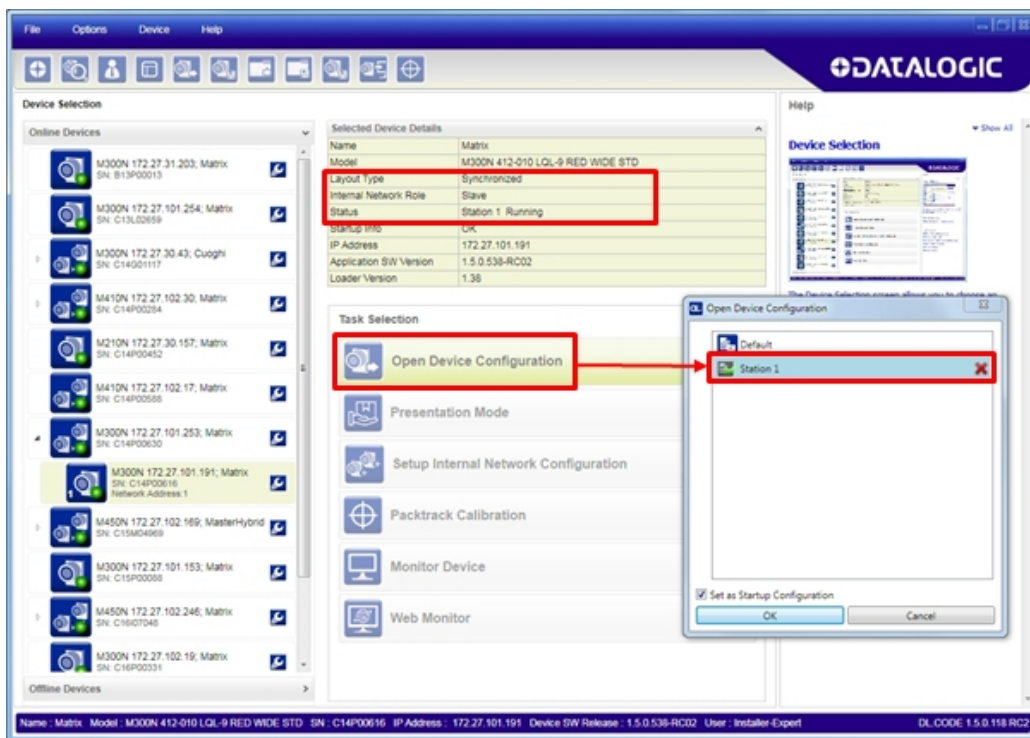

When the job opens, pause run mode and configure the Slave specific parameters. These depend on the application and include the following:

- photometric parameters (Image Auto-Setup feature in the Advanced Setup – Image Settings step)
- Acquisition Trigger Delays necessary to avoid lighting interference between adjacent or oppositely positioned readers (Reading Phase step)
- Images Saving if used (Data Formatting step)
- Encoder Sensor: if used, (for all Slaves, the Encoder Type must be set to **Internal**)

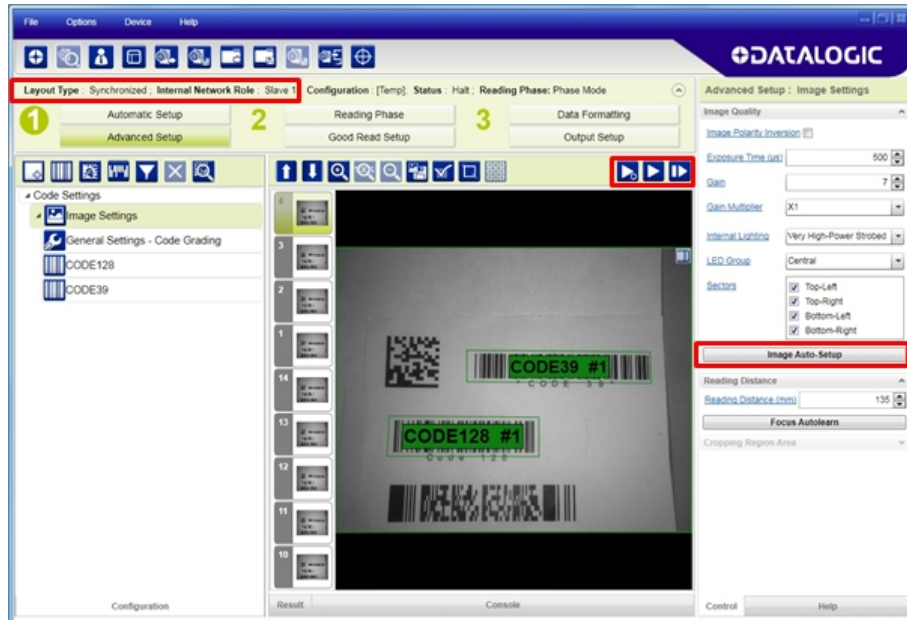

Verify the focus and decoding with the capture image button.

3. Now save them, overwriting the cloned application job¹.

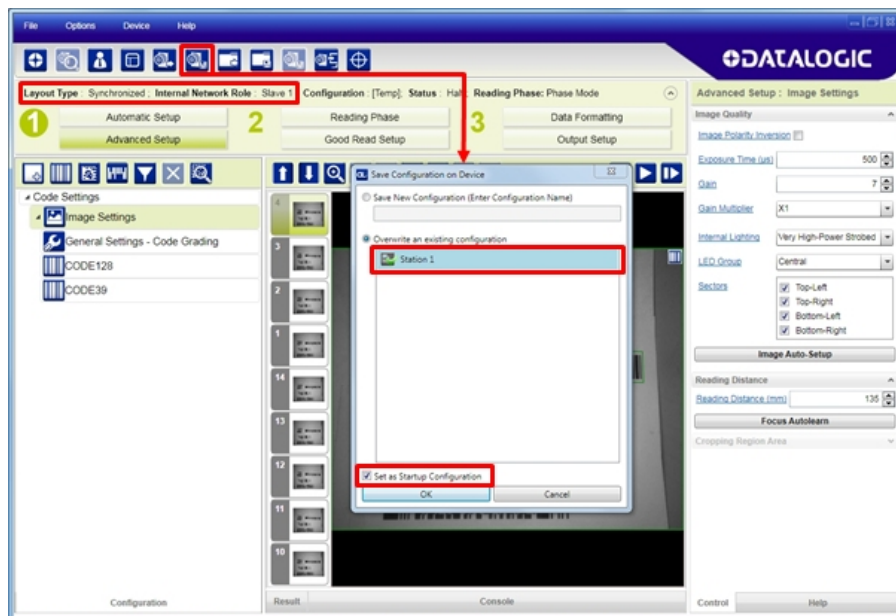

Figure 62 - Saving Synchronized Phase Mode Configuration to Slave

Repeat this procedure for each Slave device until the entire network is configured. See "ID-NET Synchronized Network" on page 58 for an example.

1. An application job with the same name as the Master's has been cloned to the Slaves. Each Slave can have its own Image Settings parameters saved in its own copy of the application job. Common parameters managed by the Master such as Operating Mode cannot be modified in the Slave jobs and are shown in dark gray.

The Reading Mask shows which device reads which Expected Code. The mask is composed of a fixed 32-character string (0=No Read or 1=Read) representing the 32 possible readers in an ID-NET network. By default the Master is the last character in the string (**Master on Right**) but this can be changed. The Slaves are shown adjacent to the Master in order (1 to 31), by default from right to left.

Example: Master + Slave 1 = 00000000000000000000000000000011

The figure above shows that both the Master and Slave 1 are reading Code 128 while only the Master is reading Code 39.

3. After verifying correct functioning of the reading devices, return the Expected Code fields from Reading Mask to Code Content.
4. If you haven't made any other changes you can exit without saving. Otherwise, save the Master device configuration overwriting its previous one, making sure to save **without Clone Master Configuration on Slaves**, otherwise the Slave configurations will be overwritten.

To view the connected Slave configurations:

1. Click on the Internal Network View tab at the bottom of the screen.
2. Open the Master branch by clicking on the arrow to the left of the Master icon.
3. Select any slave. Wait for the configuration to load.
4. Click The Configuration tab at the bottom of the screen.

By selecting the various configuration steps above you can visualize the slave configuration.

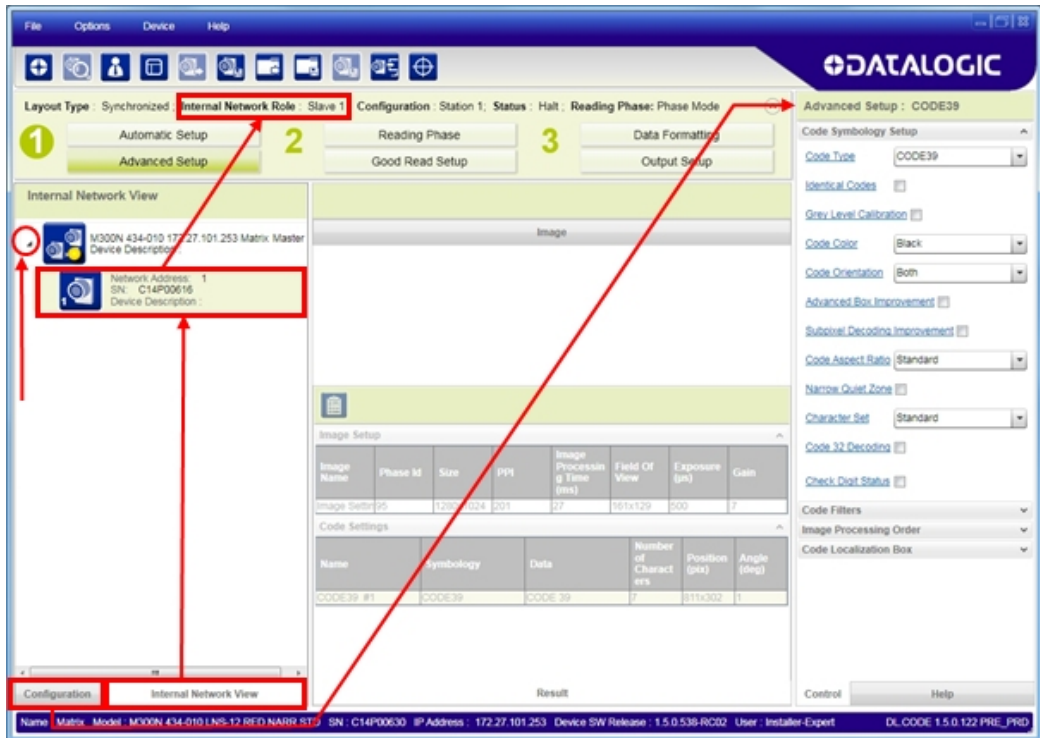

NOTE: You can modify some Slave Synchronized parameters from this view but you cannot save them here.

To save changed slave parameters here, you must click on the Master and Save the configuration overwriting it, making sure to select Save on Slave Device but **without Clone Master Configuration on Slaves**, otherwise all the Slave configuration parameters will be overwritten by the Master configuration.

DIAGNOSTIC ALARMS

By using the **DL.CODE Monitor** functions from the File menu (or Monitor icon), you can get information about diagnostic alarms. Any alarms will show up as warning lights on the alarm panel.

Monitor: Default ; Status : Halt

Alarm Code	Description	Alarm Status
1	Slave No Reply	●
64	Slave Address Duplication	●
93	Focus Motor Failure	●
124	High Temperature Warning	●
171	Protocol Index Failure	●
185	Backup Memory Communication Failure	●
187	Wrong Rotary Switch Selection	●
189	Fieldbus Communication Failure	●
191	Fieldbus Type Mismatch	●
193	Fieldbus Configuration Error	●
195	Fieldbus DHCP Problem	●
197	Low Temperature Warning	●
301	SC5000 Communication Failure	●
302	SC5000 Response Failure	●
310	Excessive Bumps Warning	●
999998	Camera Head Failure	●

Image Setup

Image Name	Phase Id	Size	PPI	Image Processing Time (ms)	Field Of View	Exposure (µs)	Gain
Image Settings	NA	1280x960	0	3	NA	400	8

Code Settings

Name	Symbology	Data	Number of Characters	Position (pix)	Angle (deg)
DMECC200 #1	DMECC200	13240K4TEA000139BMSG _6090_EB	28	829x431	1

Statistics Diagnostic Alarms Result Console

Figure 63 - Diagnostic Alarms

STATISTICS

Statistics on the reading performance can be viewed by enabling the Statistics panel from the **DL.CODE Monitor** item selected from the File menu (or Monitor icon).

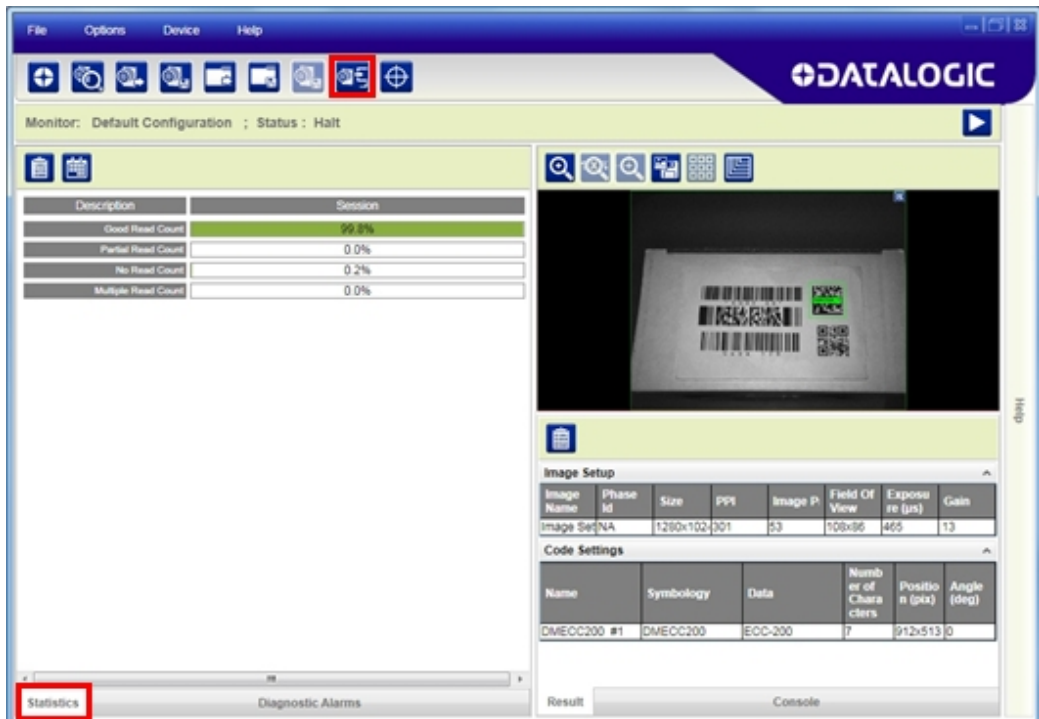
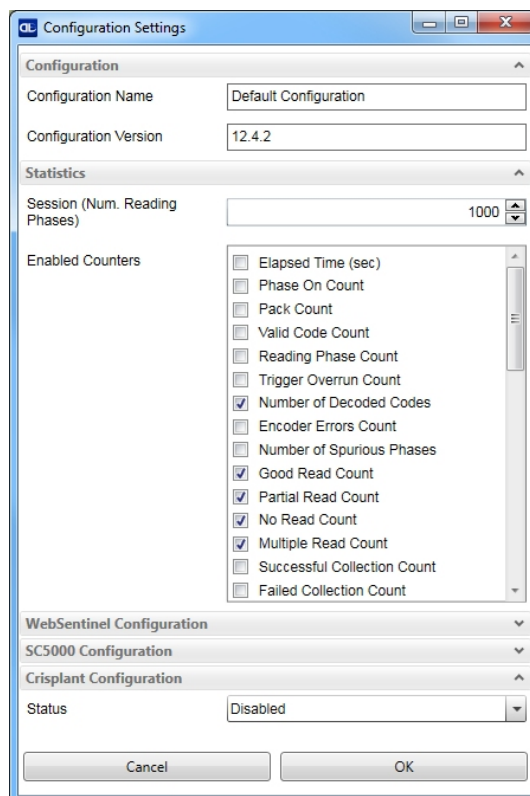

Figure 64 - Reading Statistics

The enabled Statistical Counters can be selected from the Device>Settings>Configuration Settings menu.



BM150 DISPLAY MODULE CONFIGURATION AND MESSAGES

The BM150 display module is an optional accessory for the CBX500 connection box. Although independent, it is an extension of the reader's HMI Interface, so through its keypad it provides execution of HMI features such as Test, Focus/Locate, Calibration and Code Setting. It also displays device status information, reading results, diagnostic and network messages. Since it connects through the BM100 backup memory module, it provides access to Backup and Restore features through its Extended menu.

Configuration Through DL.CODE

BM150 must be detected through the BM100 backup memory module at power-up/reset and this is done through a command setting in DL.CODE. By connecting the reader to DL.CODE the following parameters can be managed.

In the Device>Settings>Settings>Maintenance window:

- Enable BM100 Detection

Checked (Enabled): the BM100 backup memory module will be detected on power-up/reset; therefore the BM150 display module (if present), will also be enabled.

Unchecked (Disabled): the BM100 backup memory module will **not** be detected on power-up/reset; therefore the BM150 display module (if present), will also **not** be enabled.

- BM150 Display Layout (Master Only)

Reading Mask Only: the Reading Mask screen is sent to the BM150 display.

Reading Mask/Device State: the Reading Mask/Device State screen is sent to the BM150 display.

Accessing the HMI Interface Through Keypad and Display Menu

Through its keypad and display, the BM150 provides a remote extension of the reader's HMI Interface. The HMI default menu items can be accessed as well as the View menu for Master devices and the Extended menu for Backup and Restore functions.

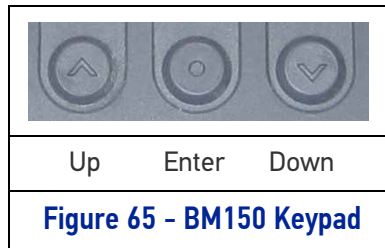

To enter the Main Menu press the **Up** and **Down** buttons simultaneously. The menu structure is shown below.

Main Menu

- **[Exit]** (exits HMI Interface menu)
- **Test Mode** (performs Test mode)
- **Focus/Locate** (performs Focus function: turns on LED pointers)
- **Calibration** (performs Setup function)
- **Code Setting** (performs Learn function)
- **Match Code Tra** (Training: allows to read a code and store it as the Match code)

View Menu (Master Only)

- **[Exit]** (returns to Main menu)
- **Standard** (displays the Standard Reading Results screen during run mode)
- **Reading Mask** (displays the Reading Mask or Reading Mask/Device State screen during run mode) depends on the selection in DL.CODE see par. Configuration Through DL.CODE.
- **Network State** (displays the Network State screen during run mode)

Extended Menu

- **[Exit]** (returns to Main menu)
- **Backup** (performs Backup - uninterruptible)
- **Restore** (performs Restore - uninterruptible)
- **Erase** (erases the backup configuration in external memory - uninterruptible)

To move through the list press and release the **Up** or **Down** key.

To select an item or enter a submenu, press and release the **Enter** key. After executing an HMI function the display shows a result message and then automatically exits from the menu structure.

To exit a menu manually, press and release the **Enter** key at the [Exit] item or press the **Up** and **Down** buttons simultaneously.

To exit from a running HMI function, press the **Up** and **Down** buttons simultaneously. These functions will also exit upon their configured timeout



NOTE: When the HMI Interface is entered from either the Local Device (reader) or Remote Device (BM150), the key(s) on the other device are disabled.



NOTE: When the reader is connected to DL.CODE, access to the BM150 HMI Interface is disabled.



NOTE: The “Reset Reader to Factory Default Environment” function of the HMI Interface is only available on the local device (reader), and not on the BM150.

Display Messages

The following examples of Remote Display messages are given to help interpret the information reported. The content of these messages depends on the connected reader.

Welcome Message

```
M M M M M M M M M M M M M
K K K V V V V V V V V V V R R R N N N
S N D D D D D D D D D D
E T H A A A . A A A . A A A . A A A
```

- M = scanner model
- K = software – STD=Standard, SS =Special
- V = software version
- R = Device Network Type – MUL=Multidata, SYN=Synchronized, ALN=Alone
- N = Device Network Setting – M00=ID-NET Network Master, Sxx= ID-NET Network Slave address, Null string= Alone (no network)
- D = device serial number
- A = Ethernet IP Address

Test Mode Results

```
A A A % Z Z Z Z Z Z Z Z Z Z Z Z Z Z Z Z Z
Z Z Z Z Z Z Z Z Z Z Z Z Z Z Z Z Z Z Z Z
Z Z Z Z Z Z Z Z Z Z Z Z Z Z Z Z Z Z Z Z
```

- A = reading percentage from 000 to 100%.
- Z = code content.

Calibration (Setup) Results

```
E x p = X X X X
G a i n = G G
C a l i b r a t i o n
O K ( p e r m a n e n t )
```

- X = exposure value (in μs).
- G = gain value

Code Setting (Learn) Results

```
X X X X X X X X X
C o d e S e t t i n g
O K ( p e r m a n e n t )
```

- X = recognized code symbology.

Diagnostic Alarms

Diagnostic error messages are sent to the BM150 display as numeric Alarm Codes, (even if Failure Messages are selected for data transmission the numeric Alarm Code is sent to the display).

```

A l e r t   :
F a i l u r e       # X X X
R R R   N N N
    
```

X = numeric Alarm Code (see below for the list of Alarm Codes)

R = Device Network Type – MUL=Multidata, SYN=Synchronized, ALN=Alone

N = Device Network Setting – M00=ID-NET Network Master, Sxx= ID-NET Network Slave address, Null string= Alone (no network)

Alarm Code	Description
1	Slave No Reply
64	Slave Address Duplication
171	Protocol Index Failure
185	Backup Memory Communication Failure
187	Wrong Rotary Switch Selection
189	Fieldbus Communication Failure
191	Fieldbus Type Mismatch
193	Fieldbus Configuration Error
195	Fieldbus DHCP Problem
201	No XRF Slave(s) Detected

Slave Node Alarms (Master only)

```

A l e r t   : I D - N E T
N o d e # X X   M i s s i n g
R R R   M 0 0
    
```

X = slave node number (1-31)

R = Device Network Type – MUL=Multidata, SYN=Synchronized

Network State (Master only)

0	N e t w o r k														1 5		
M	S	S	S	S	S	S	S	S	S	S	S	S	S	S	S	S	S
1	N e t w o r k														3 1		
S	S	S	S	S	S	S	S	S	S	S	S	S	S	S	S	S	S

M = Master diagnostic condition; S = Slave diagnostic condition:

* = scanner OK

- =scanner not detected at startup

? =scanner detected at startup but not responding to diagnostic polling

! = scanner diagnostic error

Standard Reading Results

A	A	A	A	A	A	A	A	A	A	A	A	A	A	A	A	A	A
X	X	X	X	X	X	X	X	X	X	X	X	X	X	X	X	X	X
X	X	X	X	X	X	X	X	X	X	X	X	X	X	X	X	X	X
Y	Y	C	o	d	e	s											

A = reading result – Good Read, Partial Read, Multiple Read

X = code content

Y = number of codes read

Reading Mask Only (Master Only)

X	X	X	X	X	X	X	X	X	X	X	X	X	X	X	X	X	X
G	Y	Y	Y	%	N	Y	Y	Y	%	M	Y	Y	Y	%	P	Y	Y
S	S	S	S	S	S	S	S	S	S	S	S	S	S	S	S	S	S
T	T	T	T	T	T	T	T	T	T	T	T	T	T	T	T	T	T

X = code content (or "No Read" or "Multiple Read")

Y = Good Read, No Read, Multiple Read and Partial Read counters on the last 100 codes read (%)

S = Reading Mask for Stand Alone or Master plus Slave readers 1 - 15

(0 = No Read, 1 = Good Read, M = Multiple Read)

T = Reading Mask for Slave readers 16 - 31

(0 = No Read, 1 = Good Read, M = Multiple Read)

Reading Mask/Device State (Master Only)

X	X	X	X	X	X	X	X	X	X	X	X	X	X	X	X	X	X
P	=	Y	Y	Y	Y	Y	Y	Y		G	R	=	Z	Z	Z		Z
S	S	S	S	S	S	S	S	S	S	S	S	S	S	S	S	S	S
U	U	U	U	U	U	U	U	U	U	U	U	U	U	U	U	U	U

X = Recognized code label data (or "No Read" or "Multiple Read")

Y = Phase Counter (range: 0000000 to 9999999)

Z = Good Read or Multiple Read counters (%)

S = Reading Mask for Stand Alone or Master plus Slave readers 1 - 15

(0 = No Read, 1 = Good Read, M = Multiple Read)

U = Diagnostic condition for Stand Alone or Master plus Slave readers 1 - 15:

* = reader OK

- = reader not detected at startup

? = reader detected at startup but not responding to diagnostic polling

! = reader diagnostic error

BM150 Backup and Restore Procedure

The Backup and Restore functions are valid for any application layout type (point-to-point, network, etc.) using CBX500 connection boxes through the BM100 Backup module (required accessory for BM150 installation).

The Backup and Restore functions are managed through the BM150 display and keypad and therefore are disabled at the BM100 Backup/Restore button.

If it ever becomes necessary to replace the reading device it can be quickly configured through the restore procedure.

BM150 provides complete backup and restore functions (Configuration and Environmental parameters) with the following difference:

For Single Readers or individual ID-NET Slaves:

- Backup and Restore functions provide parameter storage including all configuration jobs present on the reader.

For Master Readers in ID-NET Master/Slave networks:

- Backup and Restore functions provide parameter storage of only the Startup Configuration for the Master and all Slaves present in the network.



CAUTION: For Master/Slave networks any other configurations (jobs) stored in the device memory will not be backed up. Therefore upon a restore, all jobs other than the startup configuration will be overwritten (erased). It is strongly recommended to save all configurations to backup files.

The Slaves must always be configured with the same network baudrate as the Master for correct functioning including performing Backup and Restore procedures.

Backup and Restore functions cannot be interrupted once started.

To perform *Backup*

1. Make sure the Write Protection switch on the BM100 is unlocked.
2. Select the **Backup** item from the Extended menu and press the Enter key.
3. When the procedure is complete a message appears on the display showing the results (**Backup OK 1 File Saved** or an error message).
4. Set the Write Protection switch to locked.

To perform *Restore*

1. Select the **Restore** item from the Extended menu and press the Enter key.
2. When the procedure is complete a message appears on the display showing the results (**Restore OK 1 File Restored** or an error message).

CHAPTER 9

BACKUP AND RESTORE

There are several methods to choose from in order to backup and restore a configuration:

- "Backup and Restore Through Micro SD Card" on page 118
- "Backup and Restore Through DL.CODE" on page 119

BACKUP AND RESTORE THROUGH MICRO SD CARD

A micro SD Card can optionally be used to provide a complete backup of the reader.

When an empty SD Card is inserted, a full backup of the device is performed (including both device configuration and software version).

From this point on, every time a change is permanently saved on the reader (both configuration change and or software update), the SD Card backup will be automatically updated as well.

Each time the device is powered up, the content of the internal memory is compared with the content of the SD Card. If the two are different, the SD Card content is used to overwrite the internal memory, automatically performing a "Restore" operation.

In case a unit needs to be replaced, simply remove the SD Card from the old device, insert it in the new one (same model) and power it on.

The current status of the SD Card backup is shown by the "Backup" led in the HMI:

- Led off: no SD Card inserted
- Led solid Green: SD Card inserted, a valid backup is present
- Led solid Red: SD Card inserted, but no valid backup present (this means SD Card not readable or content not valid).



NOTE: If a SD Card with a valid Backup is inserted while the device is powered on, no immediate action will be taken. If the Backup is different from the internal memory content, the Backup led will start blinking green.

In this case:

- **To perform a restore procedure: power cycle the reader**
- **To force a Backup operation (formatting the SD Card, and so discarding its current content): use "Intit" Function of the X-Press interface**



NOTE: Micro SD Card is available as an accessory (see Micro SD Card, starting on page 141).

BACKUP AND RESTORE THROUGH DL.CODE

DL.CODE allows Backup and Restore to be performed to/from the configuration PC via file or to an external storage device such as BM100.

It can be performed for Single Reader and Internal Network (Master/Slave) configurations.

Backup and Restore functions allow performing Complete Configuration and Environment parameter storage for Single Reader and ID-NET (Master/Slave) network devices as well as device firmware. Backup and Restore can be applied to any reader connected through a device having external backup memory, regardless of the reader's network configuration.



NOTE: The Restore function is supported only when replacing devices with the same part number. It is not allowed to Restore the parameters storage, in case of device replacement between different models.

Backup to and Restore from external device is supported by DL.CODE for all reading devices when connected to:

- CBX + BM100
- QLM-Series Gateways



NOTE: Before executing a Backup to a BM100 backup module make sure the Write Protection switch is set to Unlocked.

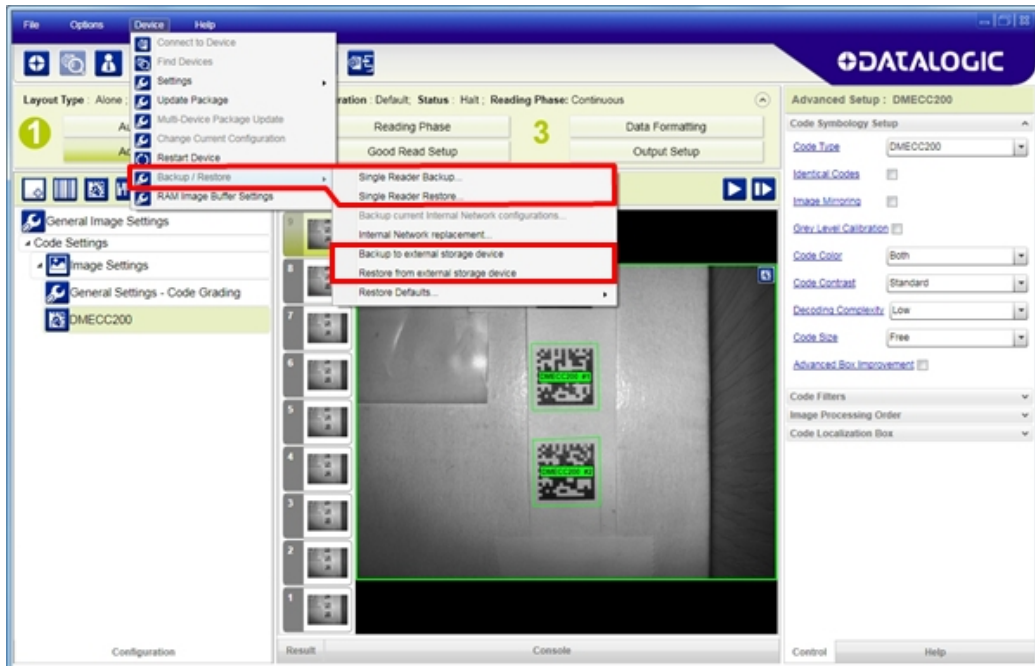

Backup

To perform a **Backup**:

1. From the DL.CODE Device menu, select either **Single Reader Backup** (to file on PC); or **Backup to external storage device**.



NOTE: For ID-NET network Backup, select the Backup current Internal Network configurations selection.

You will be reminded that configuration in temporary memory will not be saved so you should save the configuration to the reader before performing Backup.

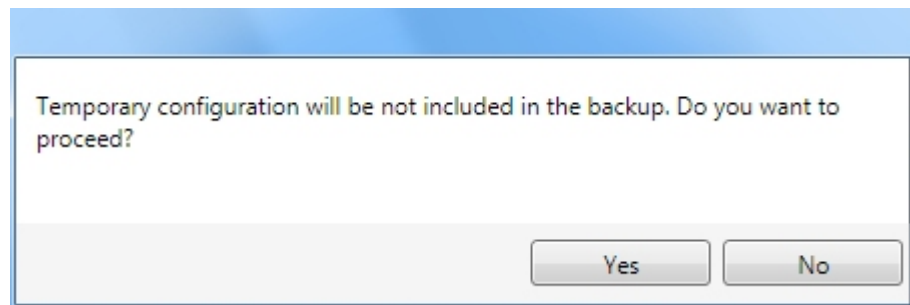

If you are performing a backup to a file you will be asked whether to include the firmware or not.

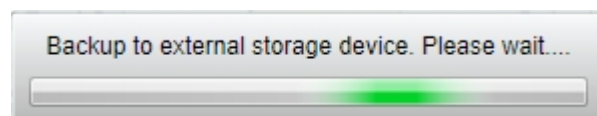
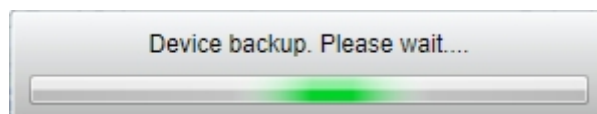
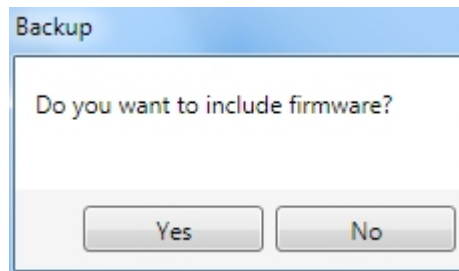

At the end of the backup, DL.CODE shows a message indicating successful completion.

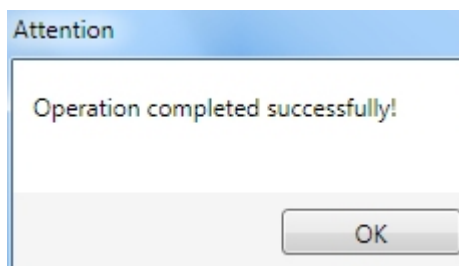

Restore

To perform a **Restore**:

1. From the DL.CODE Device menu, select either **Single Reader Restore** (from file on PC); or **Restore from external storage device**.



NOTE: For ID-NET network Restore, select the Internal Network replacement selection.



If restoring an ID-NET network through the Master, this may take a few minutes.

At the end of the restore, DL.CODE shows a message indicating successful completion.

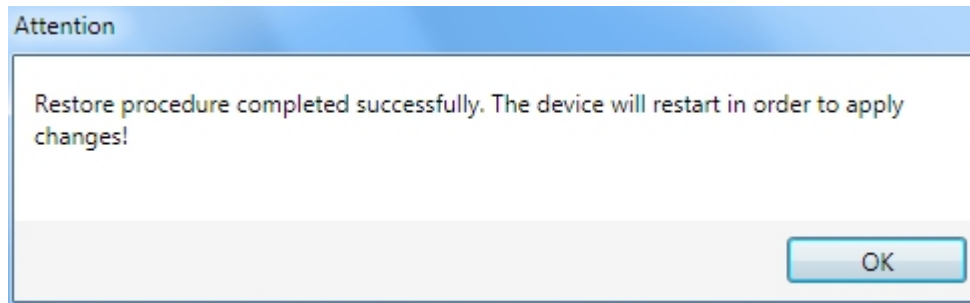

Replacement



CAUTION: The replacement device must be the exact same model as the device it is replacing, i.e. both devices must have the same part number.

The **Restore** function also provides easy and secure Single Device Replacement:

1. Remove the device to be replaced.
2. Connect the new device (make sure the new device has been previously set to factory default).
3. Run the Restore procedure by selecting either **Single Reader Restore** (from file on PC) or **Restore from external storage device** item (see: Restore procedure).



NOTE: In case of Backup or Restore operation failures, error messages will be displayed in the Monitor Diagnostic page.

Restore Defaults

The device parameters are divided into two main classes, Configuration and Environment which are affected differently by the Restore Defaults commands.

- The Configuration parameters are the ones set in the various steps of the configuration process and are specific to each application. When multiple configurations (jobs) are saved on a single device, these parameters can be different from one configuration to the next.
- Environment parameters regard the device Identity and Position in a Network (Ethernet, ID-NET, etc.) and are not influenced by the Default (or any other) Configuration present in memory.

Restore Default Startup Configuration

The Default configuration is always present on the reader and in fact it is not modifiable and cannot be deleted. It can always be restored by simply selecting it from the Open from Device configuration list.

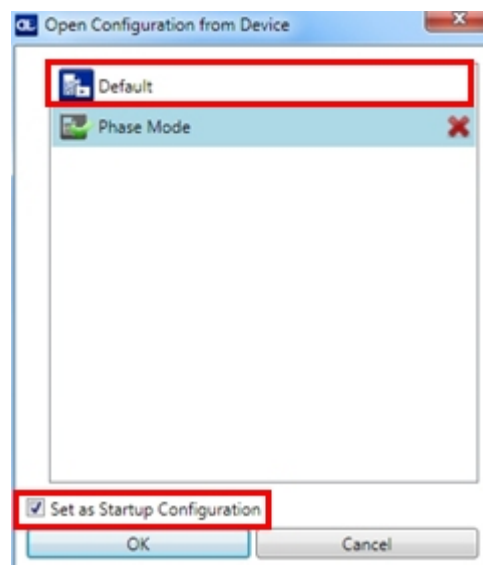

The same action can be performed from the Device menu >Backup/Restore > Restore Defaults > **Restore Default Startup Configuration**. The Default Configuration will be set to run at startup and the reader will be reset.

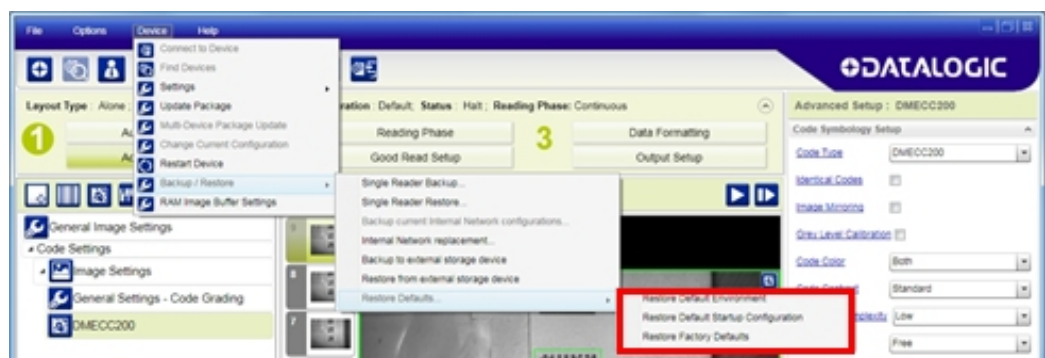

Any previously saved configurations on the device will remain in memory, but the Default configuration is set as the startup configuration.

Restore Default Environment

Restore Default Environment returns all Environment parameters to their factory default settings. The default IP address will be restored as well as all the parameters managed in the Device Environment Configuration window.

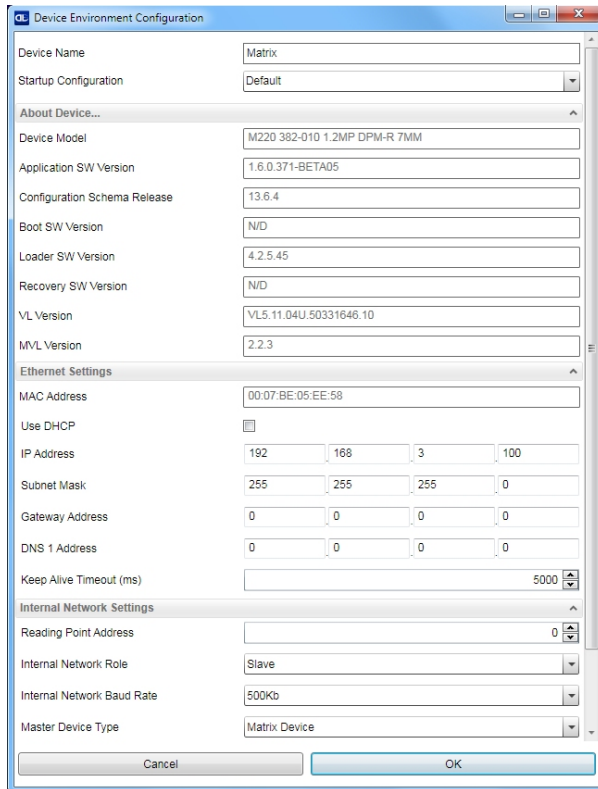

The Factory Default static IP address for all Matrix N Family readers is:

IP Address = 192.168.3.100

Any previously saved configurations on the device will remain in memory, but the Default configuration is set as the startup configuration.

Restore Factory Defaults

In order to return a device to its absolute Factory default parameters (for example device replacement) it is necessary to use the **Restore Factory Defaults** command. You will be prompted to confirm.

All Environment parameters will be restored to Factory default values **and any existing configurations stored on the device will be erased**. The device will be reset and therefore start in run mode with the factory default configuration.

CHAPTER 10

MAINTENANCE

CLEANING

Clean the lens cover periodically for continued correct operation of the reader. See "General View" on page 16.

Dust, dirt, etc. on the lens cover may alter the reading performance.

Repeat the operation frequently in particularly dirty environments.

Use soft material and alcohol to clean the lens cover and avoid any abrasive substances.

CHAPTER 11

TROUBLESHOOTING

GENERAL GUIDELINES

- When wiring the device, pay careful attention to the signal name (acronym) on the CBX100/500 spring clamp connectors ("[Electrical Connections](#)" on page 29). If you are connecting directly to the Blade M12 17-pin connector, pay attention to the pin number of the signals ([Appendix A](#)).
- If you need information about a certain reader parameter you can refer to the DL.CODE help on line. Connect the device and click on the link to the parameter you're interested in.
- If you're unable to fix the problem and you're going to contact your local Datalogic office or Datalogic Partner or ARC, we suggest providing (if possible): Application Program version, Parameter Configuration file, Serial Number and Order Number of your reader. You can get most of this information while DL.CODE is connected to the reader.

Troubleshooting Guide	
Problem	Suggestion
DL.CODE Installation: Autorun or Start.hta doesn't run	Check Windows settings to see if Autorun is disabled. Associate the file type <code>.hta</code> with the Microsoft HTML Application host mshta.exe in Windows\System32.
Power ON: the "POWER" LED is not lit.	Is power connected? If using a power adapter (like PG6000), is it connected to wall outlet? If using rail power, does rail have power? If using CBX, does it have power (check switch and LED)? Check if you are referring to the M12 17-pin connector or to the CBX spring clamp connectors. Measure Voltage either at pin 1 and pin 2 (for 17-pin connector) or at spring clamp Vdc and GND (for CBX).

Troubleshooting Guide	
Problem	Suggestion
<p>One Shot or Phase Mode using the Input 1 (External Trigger) or Input 2: the "TRIGGER" LED is not blinking while the External Trigger is switching.</p>	<p>Check if you are referring to the 17-pin connector or to the CBX spring clamp connectors.</p> <p>Is the sensor connected to Input 1 or Input 2?</p> <p>Is power supplied to the photo sensor?</p> <p>For NPN configuration, is power supplied to one of the two I1 or I2 signals (A or B)?</p> <p>For PNP configuration, is one of the two I1 or I2 signals grounded (A or B)?</p> <p>Are the photo sensor LEDS (if any) working correctly?</p> <p>Is the sensor/reflector system aligned (if present)?</p> <p>On the Reading Phase step check the Input 1 or Input 2 <i>Debounce Time</i> parameter setting.</p> <p>On the Reading Phase step check the settings for <i>Acquisition Trigger</i>, <i>Reading Phase-ON</i>, and <i>Reading Phase-OFF</i> parameters.</p>
<p>One Shot or Phase Mode using serial trigger source: the "TRIGGER" LED is not blinking.</p>	<p>On the Reading Phase step check the settings for <i>Acquisition Trigger</i>, <i>Reading Phase-ON</i>, and <i>Reading Phase-OFF</i> parameters.</p> <p>Are the COM port parameters (<i>Baud Rate</i>, <i>Parity</i>, <i>Data Bits</i>, <i>Stop Bits</i>) correctly assigned?</p> <p>On the Reading Phase step check the settings of <i>Acquisition Trigger String</i>, <i>Reading Phase-ON String</i>, and <i>Reading Phase-OFF String</i> parameters.</p> <p>Is the serial trigger source correctly connected?</p>
<p>Phase Mode: the "TRIGGER" LED is correctly blinking but no image is displayed in the DL.CODE window.</p>	<p>Is the Phase frequency lower than the maximum frame rate?</p>
<p>Continuous Mode: the "TRIGGER" LED is not blinking.</p>	<p>Verify the correct software configuration settings.</p>
<p>Any Operating Mode: the "TRIGGER" LED is correctly blinking but no result is transmitted by the reader at the end of the reading phase collection.</p>	<p>Check the Code Collection parameters on the Reading Phase step and the Data Formatting parameters on the Data Formatting step.</p>
<p>Image not clear:</p>	<p>verify the Focus procedure</p>
<p>Image focused but not decoded:</p>	<p>verify the Calibrate Image Density procedure.</p>

Troubleshooting Guide	
Problem	Suggestion
<p>Reading: the reader always transmits the <i>No Read Message</i></p>	<p>Run the Rapid Configuration procedure in "Rapid Configuration" on page 19.</p> <p>Position the reader as described in "Mounting And Positioning Blade" on page 27 and through DL.CODE:</p> <p>Tune the Acquisition Delay on Trigger, if the moving code is out of the reader field of view;</p> <p>Set the Continuous Operating Mode if no external trigger source is available;</p> <p>Tune the Image Settings to improve the code image quality;</p> <p>Check the parameter settings in the Advanced Setup step: 1D Codes, and Postal Codes;</p> <p>View the full resolution code image to check the printing or marking quality.</p>
<p>Communication: reader is not transmitting anything to the host.</p>	<p>Is the serial cable wiring correct?</p> <p>If using CBX, be sure the RS422 termination switch is OFF.</p> <p>Are the host serial port settings the same as the reader serial port settings?</p> <p>In DL.CODE Device menu > Settings > Settings > LED Configuration, the COM LED Function can be configured to indicate Main Serial Port TX or Main Serial Port RX.</p>
<p>Communication: data transferred to the host are incorrect, corrupted or incomplete.</p>	<p>Are the host serial port settings the same as the reader serial port settings?</p> <p>In the DL.CODE Data Formatting step check the settings of Header and Terminator String parameters.</p> <p>In the DL.CODE Data Formatting step, check the various Message Field parameter settings.</p>
<p>Configuration: cannot access environment parameters in DL.CODE (Device>Settings>Settings menu item is grey)</p>	<p>Are you using the Installer - Expert User level? If not change it in the Options>Change User menu.</p>
<p>How do I obtain my reader Serial Number?</p>	<p>The reader Serial Number consists of 9 characters: one letter, 2 numbers, another letter followed by 5 numbers.</p> <p>The reader Serial Number is printed on a label that is affixed to the case or connector block of the reader.</p> <p>The Serial Number is also visible from the DL.CODE Device List Area.</p>
<p>How do I obtain my reader Order Number?</p>	<p>The reader Order Number consists of 9 numbers.</p> <p>The reader Order Number can be obtained by comparing the Device Model (in DL.CODE Device Menu > Settings > Settings > About Device) with the product models page on the Datalogic website.</p>

APPENDIX A

TECHNICAL FEATURES

ELECTRICAL FEATURES		
	Blade 100	Blade 200
Power		
Supply Voltage	10 to 30 Vdc	
Max Consumption	0.45 A	0.50 A
Communication Interfaces		
RS232	2400 to 115200 bit/s	2400 to 115200 bit/s
RS422 Full-duplex		2400 to 115200 bit/s
ID-NET™ ¹	Up to 1 Mbaud	
Ethernet	10/100 Mbit/s	
Inputs		
	Opto-coupled and polarity insensitive ²	
Max. Voltage	30 Vdc	
Max. Input Current	10 mA	
Outputs³		
Output 1, 2 and 3	NPN or PNP short circuit protected;	
V _{OUT} (I _{LOAD} = 0 mA) Max.	30 Vdc	
V _{OUT} (I _{LOAD} = 100 mA) Max.	3 Vdc	
I _{LOAD} Max.	100 mA	

1. x1xxx models only
2. Two inputs for x1xxx models and one input for x2xx and x3xx models
3. x1xxx models only. When connected to the CBX connection boxes the electrical features for Output 1 and 2 become the following:
 Opto-isolated; V_{CE} = 30 Vdc max.; I_{CE} = 40 mA continuous max.; 130 mA pulsed max.;
 V_{CE saturation} = 1 Vdc max. @ 10 mA; P_D = 90 mW Max. @ 50 °C ambient temp.

OPTICAL FEATURES		
	Blade 100	Blade 200
Image Sensor	CMOS sensor with Global Shutter	
Image Format	1920 x 128 pixels	
Frame Rate	up to 270 frames per second	
LED Safety	"EXEMPT RISK GROUP" according to IEC62471	
Lighting System	Red Internal Illuminator	
Reading distance	40 - 320 mm 1.57 - 12.6 in	40 - 600 mm 1.57 - 23.62 in

ENVIRONMENTAL FEATURES	
Operating Temperature	0 to 50 °C (32 to 122 °F)
Storage Temperature	-20 to 70 °C (-4 to 158 °F)
Max. Humidity	90% non condensing
Vibration Resistance EN 60068-2-6	14 mm @ 2 to 10 Hz; 1.5 mm @ 13 to 55 Hz; 2 g @ 70 to 500 Hz; 2 hours on each axis
Shock Resistance EN 60068-2-27	30g; 11 ms; 3 shocks on each axis
Protection Class EN 60529	IP65

PHYSICAL FEATURES	
Dimensions (connectors at 0°)	H x W x L
x1xxx models	83 x 68 x 38 mm (3.27 x 2.68 x 1.5 in)
x2xxx-x3xxx models	104 x 86 x 35.8 mm (4.1 x 3.38 x 1.41 in)
Weight	310 g. (10.93 oz.)
Material	Aluminium

SOFTWARE FEATURES	
Readable Code Symbologies	1D and Stacked

SOFTWARE FEATURES

- PDF417 Standard and Micro PDF417
- Code 128 (GS1-128)
- Code 39 (Standard and Full ASCII)
- Code 32
- MSI
- Standard 2 of 5
- Matrix 2 of 5
- Interleaved 2 of 5
- Codabar
- Code 93
- Pharmacode
- EAN-8/13 - UPC-A/E (including Addon 2 and Addon 5)
- GS1 DataBar Family
- Composite Symbologies

Operating Mode	Continuous, Phase Mode
Configuration Methods	X-PRESS Human Machine Interface Windows-based SW (DL.CODE) via Ethernet Interface Host Mode Programming sequences sent over Serial or Ethernet TCP interfaces
Parameter Storage	Permanent memory (Flash)

APPENDIX B

ALTERNATIVE CONNECTIONS

The connector pinouts and notes given in this appendix are for custom cabling applications.

Power and I/O Connector

The Power and I/O connector varies by model.

In order to meet EMC requirements:

- connect the reader chassis to the plant earth ground by means of a flat copper braid shorter than 100 mm;
- connect your cable shield to the locking ring nut of the connector.

Ethernet Connector

A Standard M12 4-pin D-Coded female connector is provided for the on-board Ethernet connection. This interface is IEEE 802.3 10 BaseT and IEEE 802.3u 100 BaseTx compliant.

ETHERNET MODELS

Power, Com and I/O connector

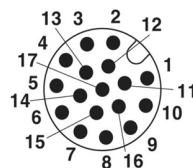

Figure 1 - M12 17-pin male

PIN	NAME	FUNCTION	
1	Vdc	Power supply input voltage +	
2	GND	Power supply input voltage -	
Connector case	CHASSIS	Connector case provides electrical connection to the chassis	
6	I1A	External Trigger A (polarity insensitive)	
5	I1B	External Trigger B (polarity insensitive)	
13	I2A	Input 2 A (polarity insensitive)	
3	I2B	Input 2 B (polarity insensitive)	
9	O1	Output 1	(NPN or PNP short circuit protected and software programmable)
8	O2	Output 2	
16	-	-	
14	RX	Auxiliary RS232 RX	
4	TX	Auxiliary RS232 TX	
7	ID+	ID-NET network data +	
15	ID-	ID-NET network data -	
		RS232	RS422 Full-Duplex¹
17	Main Interface (SW Selectable)	TX	TX+
11		RX	RX+ ²
12		-	TX-
10		-	RX- ²

1. Blade 200 models only
2. Do not leave floating, see "RS422 Full Duplex Interface" on page 36 for connection details

Ethernet connector

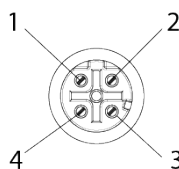

Figure 2- M12 D-Code 4-pin female

PIN	NAME	FUNCTION
1	TX+	Transmit data (positive pin)
2	TX-	Transmit data (negative pin)
3	RX+	Receive data (positive pin)
4	RX-	Receive data (negative pin)

FIELDBUS MODELS

Power and I/O connector

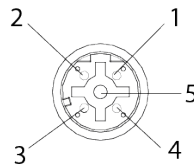

Figure 3 - M12 A-code 5-pin male

PIN	NAME	FUNCTION
1	Vdc	Power supply input voltage +
2	IA	Input A (polarity insensitive)
3	GND	Power supply input voltage -
4	IB	Input B (polarity insensitive)
5	-	-

Ethernet connector 1

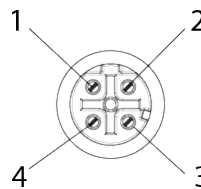

Figure 4- M12 D-Code 4-pin female

PIN	NAME	FUNCTION
1	TX+	Transmit data (positive pin)
2	TX-	Transmit data (negative pin)
3	RX+	Receive data (positive pin)
4	RX-	Receive data (negative pin)

Ethernet connector 2

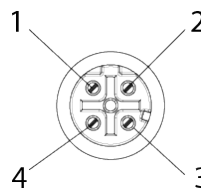

Figure 5- M12 D-Code 4-pin female

PIN	NAME	FUNCTION
1	TX+	Transmit data (positive pin)
2	TX-	Transmit data (negative pin)
3	RX+	Receive data (positive pin)
4	RX-	Receive data (negative pin)

ID-NET NETWORK TERMINATION

The network must be properly terminated by a 120 Ohm resistor at the first and last reader of the network.

INPUTS

There are two optocoupled polarity insensitive inputs available on the M12 17-pin connector of the reader: Input 1 (External Trigger) and Input 2, a generic input. See "Inputs" on page 43 for more details.

The electrical features of both inputs are:

INPUT	$ V_{AB} $ MIN.	$ V_{AB} $ MAX.	I_{IN} MAX.
Open	0 V	2 V	0 mA
Closed	4.5 V	30 V	10 mA

The relative pins on the M12 17-pin connector are:

INPUT PINOUT		
PIN	NAME	DESCRIPTION
1	Vdc	Power Supply input voltage +
6	I1A	External Trigger A (polarity insensitive)
5	I1B	External Trigger B (polarity insensitive)
13	I2A	Input 2 A (polarity insensitive)
3	I2B	Input 2 B (polarity insensitive)
2	GND	Power Supply input voltage -

OUTPUTS

Three general purpose **non opto-isolated** but short circuit protected outputs are available on the M12 17-pin connector.

The pinout is the following:

OUTPUT PINOUT		
PIN	NAME	DESCRIPTION
9	O1	Configurable digital output 1
8	O2	Configurable digital output 2
2	GND	Output reference signal

The electrical features of the three outputs are the following:

Reverse-Polarity and Short-Circuit Protected

V_{OUT} ($I_{LOAD} = 0$ mA) max = 30 Vdc

V_{OUT} ($I_{LOAD} = 100$ mA) max = 3 Vdc

I_{LOAD} max = 100 mA

The output signals are fully programmable being determined by the configured Activation/Deactivation events, Deactivation Timeout or a combination of the two. For further details refer to the Help On Line page for the Output Setup step in DL.CODE.

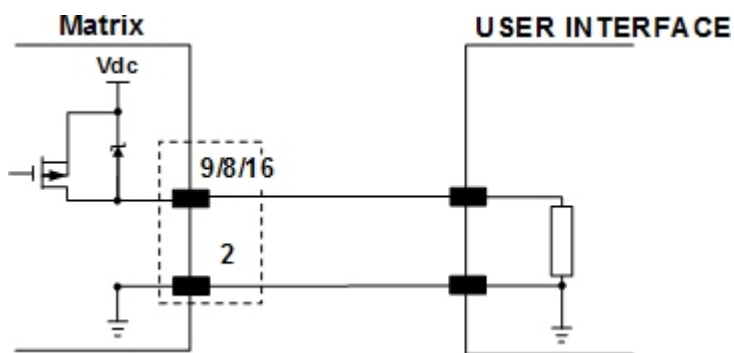

Figure 6 - PNP Output Connection

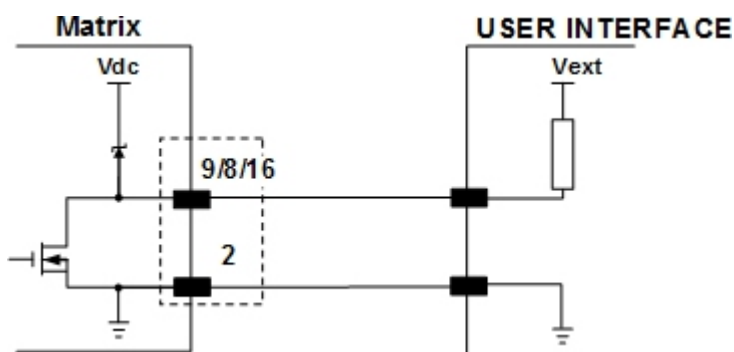

Figure 7 - NPN Output Connection



CAUTION: For NPN output connections, the external interface voltage (V_{ext}) must not exceed the Blade power supply source voltage (V_{dc}) otherwise correct output functioning cannot be guaranteed.

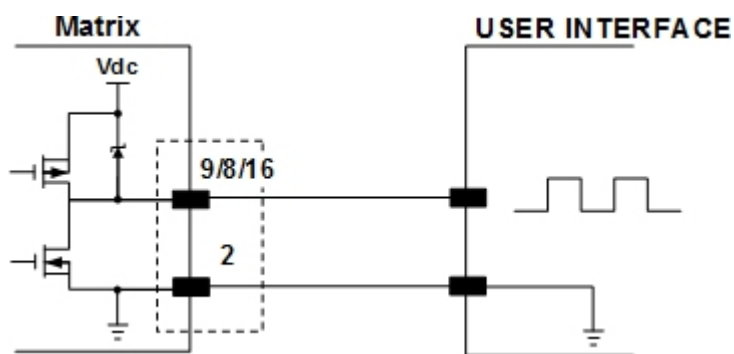
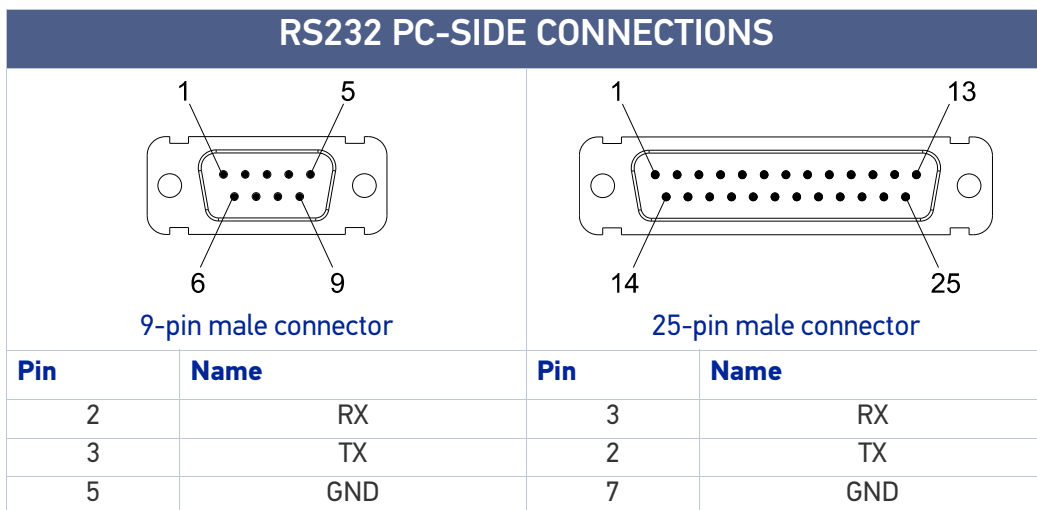

Figure 8 - Push-Pull Output Connection

USER INTERFACE - SERIAL HOST



How To Build A Simple Interface Test Cable:

The following wiring diagram shows a simple test cable including power, external (push-button) trigger and PC RS232 COM port connections.

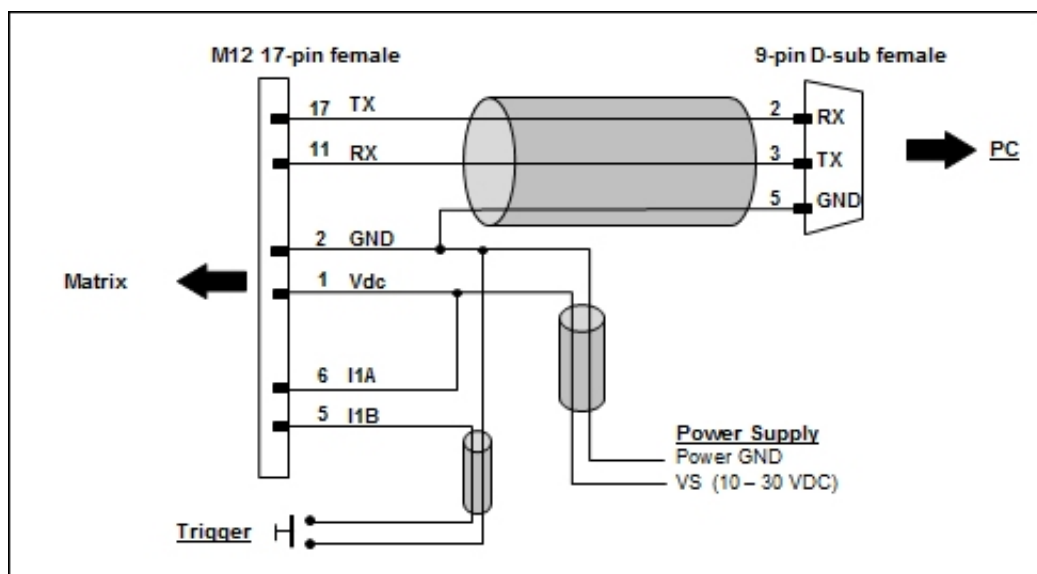

Figure 9 - Test Cable

OTHER AVAILABLE ACCESSORIES

Accessory	Description	Order No.
Cables		
CAB-DS01-S	M12-IP67 Cable To CBX or QL (1M)	93A050058
CAB-DS03-S	M12-IP67 Cable To CBX or QL (3M)	93A050059
CAB-DS05-S	M12-IP67 Cable To CBX or QL (5M)	93A050060
CAB-GD03	CAB-GD03 M12 F/L 3M	93A050076
CAB-GD05	CAB-GD05 M12 F/L 5M	93A050077
CAB-GD10	CAB-GD10 M12 F/L 10M	93A050078
CAB-ETH-M01	M12-RJ45 IP67 Ethernet Cable (1M)	93A051346
CAB-ETH-M03	M12-RJ45 IP67 Ethernet Cable (3M)	93A051347
CAB-ETH-M05	M12-RJ45 IP67 Ethernet Cable (5M)	93A051348
CBL-1534.02	Adapter Cable Ethernet M12 to RJ45	93A050057
CBL-1480-0.3	CBL-1480-0.3 M12/5P MALE/FEM. 0.3M IDNET	93A050048
CBL-1480-01	CBL-1480-01 M12/5P MALE/FEM. 1M IDNET	93A050049
CBL-1480-02	CBL-1480-02 M12/5P MALE/FEM. 2M IDNET	93A050050
CBL-1480-03	CBL-1480-03 M12/5P MALE/FEM. 3M IDNET	93A050143
CBL-1480-05	CBL-1480-05 M12/5P MALE/FEM. 5M IDNET	93A050051
CBL-1490	Term. Resist. Thin M12/5P/Male	93A050046
CBL-1496	Term. Resist. Thin M12/5P/Female	93A050047
ETH CABLE M12-M12 1M	M12-M12 Ethernet Cable (1M) for Profinet models	93A050065
ETH CABLE M12-M12 3M	M12-M12 Ethernet Cable (3M) for Profinet models	93A050066
ETH CABLE M12-M12 5M	M12-M12 Ethernet Cable (5M) for Profinet models	93A050067
CS-A1-02-G-03	M12 4PF-Wires Power Cable (3M) for Profinet models	95A251380
CS-A1-02-O-10	M12 4PF-Wires Power Cable (10M) for Profinet models	95A251090
AS-I Power Backbone	PWR Cable, AS-I, 2 Wires, 10M	93ACC0081
AS-I Power Backbone	PWR Cable, AS-I, 2 Wires, 25M	93ACC0082
AS-I Power Branch	PWR Cable M12-ASI standard-1M	93ACC0067
AS-I Power Branch	PWR Cable M12-ASI standard-2M	93ACC0068
Connectivity		
CBX100	Compact Connection Box	93A301067
CBX500	Modular Connection Box	93A301068
BM100	Backup Module for CBX100/500	93ACC1808
BM150	Display Module for CBX500	93ACC1809
Various Fieldbus Host Interface Modules and All-In-One Connection Box Kits available		
BA100	DIN Rail Adapters	93ACC1821

Accessory	Description	Order No.
BA200	Bosch and 80/20 Profile Adapters	93ACC1822
Various M12 Panel Connectors for CBX Connection Boxes available		
BA900	Two Cable Glands Panel	93ACC1847
QL100	Quick Link Slave ID-NET T-Connector	93ACC1860
QL150	Quick Link Slave ID-NET + Service T-Connector	93ACC1868
QL200	Quick Link Slave ID-NET + Power T-Connector	93ACC1861
QL300	Quick Link Master ID-NET - Serial Host Connector	93ACC1862
QLM500	Quick Link Metal Master ID-NET - Ethernet/IP Gateway	93ACC0037
QLM600	Quick Link Metal Master ID-NET - Profibus Gateway	93ACC0033
QLM700	Quick Link Metal Master ID-NET - Profinet I/O Gateway	93ACC0038
Various M12 Service Cables and Field Mount Connectors available for Quick Link Series Connectors		
Power Supplies		
PG6002	AC/DC Power Supply Unit (US)	93ACC1718
PG6001	AC/DC Power Supply Unit (UK)	93ACC1719
PG6000	AC/DC Power Supply Unit (EU)	93ACC1720
Sensors		
MEP-593	Photocell Kit PNP (PH-1)	93ACC1791
MEP-543	Photocell Kit-NPN	93ACC1728
S3Z-PR-5-C11-PL	Diffuse Proximity Sensor	95B010011
Micro SD Card		
	MicroSD Card - 8G - SIS - Blank	90ACC0520

GLOSSARY

AIM

(Association for Automatic Identification and Mobility): AIM Global is the international trade association representing automatic identification and mobility technology solution providers.

AIM DPM Quality Guideline

Standard applicable to the symbol quality assessment of direct part marking (DPM) performed in using two-dimensional bar code symbols. It defines modifications to the measurement and grading of several symbol quality parameters.

Barcodes (1D Codes)

A pattern of variable-width bars and spaces which represents numeric or alphanumeric data in machine-readable form. The general format of a barcode symbol consists of a leading margin, start character, data or message character, check character (if any), stop character, and trailing margin. Within this framework, each recognizable symbology uses its own unique format.

BIOS

Basic Input Output System. A collection of ROM-based code with a standard API used to interface with standard PC hardware.

Bit

Binary digit. One bit is the basic unit of binary information. Generally, eight consecutive bits compose one byte of data. The pattern of 0 and 1 values within the byte determines its meaning.

Bits per Second (bps)

Number of bits transmitted or received per second.

Bright Field Illumination

Lighting of surfaces at high (narrow) angles used to provide maximum reflection of the light to the reader's lens. This is effective on surfaces that absorb light or are not highly reflective and also on low contrast codes.

Byte

On an addressable boundary, eight adjacent binary digits (0 and 1) combined in a pattern to represent a specific character or numeric value. Bits are numbered from the right, 0 through 7, with bit 0 the low-order bit. One byte in memory can be used to store one ASCII character.

Composite Symbologies

Consist of a linear component, which encodes the item's primary data, and an adjacent 2D composite component, which encodes supplementary data to the linear component.

Dark Field Illumination

Lighting of surfaces at wide angles used to avoid direct reflection of the light into the reader's lens. Typically this type of lighting is used in DPM solutions to enhance reflectance of the uneven surface due to the symbol marking technique. It is also used with very reflective surfaces.

Decode

To recognize a barcode symbology (*e.g.*, Codabar, Code 128, Code 3 of 9, UPC/EAN, etc.) and analyze the content of the barcode scanned.

Depth of Field

The difference between the minimum and the maximum distance of the object in the field of view that appears to be in focus.

Diffused Illumination

Distributed soft lighting from a wide variety of angles used to eliminate shadows and direct reflection effects from highly reflective surfaces.

Direct Part Mark (DPM)

A symbol marked on an object using specific techniques like dot peening, laser etching, chemical etching, etc.

EEPROM

Electrically Erasable Programmable Read-Only Memory. An on-board non-volatile memory chip.

Element

The basic unit of data encoding in a 1D or 2D symbol. A single bar, space, cell, dot.

Exposure Time

For digital cameras based on image sensors equipped with an electronic shutter, it defines the time during which the image will be exposed to the sensor to be acquired.

Flash

Non-volatile memory for storing application and configuration files.

Host

A computer that serves other terminals in a network, providing services such as network control, database access, special programs, supervisory programs, or programming languages.

Image Processing

Any form of information processing for which the input is an image and the output is for instance a set of features of the image.

Image Resolution

The number of rows and columns of pixels in an image. The total number of pixels of an image sensor.

Image Sensor

Device converting a visual image to an electric signal. It is usually an array of CCD (Charge Coupled Devices) or CMOS (Complementary Metal Oxide Semiconductor) pixel sensors.

IEC

(International Electrotechnical Commission): Global organization that publishes international standards for electrical, electronic, and other technologies.

IP Address

The terminal's network address. Networks use IP addresses to determine where to send data that is being transmitted over a network. An IP address is a 32-bit number referred to as a series of 8-bit numbers in decimal dot notation (e.g., 130.24.34.03). The highest 8-bit number you can use is 254.

ISO

(International Organization for Standardization): A network of the national standards institutes of several countries producing world-wide industrial and commercial standards.

LED (Light Emitting Diode)

A low power electronic light source commonly used as an indicator light. It uses less power than an incandescent light bulb but more than a Liquid Crystal Display (LCD).

LED Illuminator

LED technology used as an extended lighting source in which extra optics added to the chip allow it to emit a complex radiated light pattern.

Matrix Symbologies (2D Codes)

An arrangement of regular polygon shaped cells where the center-to-center distance of adjacent elements is uniform. Matrix symbols may include recognition patterns which do not follow the same rules as the other elements within the symbol.

Multi-row (or Stacked) Symbologies

Symbologies where a long symbol is broken into sections and stacked one upon another similar to sentences in a paragraph.

RAM

Random Access Memory. Data in RAM can be accessed in random order, and quickly written and read.

Symbol Verification

The act of processing a code to determine whether or not it meets specific requirements.

Transmission Control Protocol/Internet Protocol (TCP/IP)

A suite of standard network protocols that were originally used in UNIX environments but are now used in many others. The TCP governs sequenced data; the IP governs packet forwarding. TCP/IP is the primary protocol that defines the Internet.

©2024 Datalogic S.p.A. and /or its affiliates • All rights reserved • Without limiting the rights under copyright, no part of this documentation may be reproduced, stored in or introduced into a retrieval system, or transmitted in any form or by any means, or for any purpose, without the express written permission of Datalogic S.p.A. and/or its affiliates • Datalogic and the Datalogic logo are registered trademarks of Datalogic S.p.A. in many countries, including the U.S. and the E.U.



DATALOGIC
www.datalogic.com

Datalogic S.r.l.

Via S. Vitalino, 13 | 40012 Calderara di Reno | Bologna - Italy
Tel. +39 051 3147011 | Fax +39 051 3147205



801000390

(Rev. B)

December 2024